



## FEATURES

- n Single-chip PC Card host adapters
- n Direct connection to ISA (PC AT) bus and one or two PC Card sockets
- n Compliant with PC Card Standard, PCMCIA 2.1, and JEIDA 4.1
- n 82365SL-compatible register set, ExCA™-compatible
- n Automatic Low-Power Dynamic mode for lowest active power consumption
- n Programmable Suspend mode
- n Hardware-enabled Super Suspend mode
- n Five programmable memory windows per socket and two programmable I/O windows per socket
- n Programmable card access cycle timing
- n 8- or 16-bit system bus interface
- n 8- and 16-bit PC Card interface support
- n ATA disk interface support
- n DMA support (VG-PD6722)
- n Card-voltage sense support
- n PC Card activity indicator
- n Mixed-voltage operation (3.3/5.0 V)
- n Single-socket interface: 144-pin VQFP for smallest form factor (CL-PD6710)
- n Dual-socket interface: 208-pin PQFP or VQFP (VG-PD6722)

## ISA-to-PC-Card Host Adapters

## OVERVIEW

The CL-PD6710 and VG-PD6722 are single-chip PC Card host adapter solutions capable of controlling one (CL-PD6710) or two (VG-PD6722) PC Card sockets. The chips are compliant with PC Card Standard, PCMCIA 2.1, and JEIDA 4.1 and are optimized for use in notebook and handheld computers where reduced form factor and low power consumption are critical design objectives. With the CL-PD6710, a complete PC Card solution with power-control logic can occupy less than 1.5 square inches (excluding the socket connector). With the VG-PD6722, a complete dual-socket PC Card solution with power-control logic can occupy less than 2 square inches (excluding socket connectors).

The chips employ energy-efficient mixed-voltage technology that can reduce system power consumption by over 50 percent. The chips also provide: a Low-Power Dynamic mode, which automatically stops the internal clock during periods of card inactivity; a software-controlled Suspend mode, which dramatically reduces power by disabling most of the internal circuitry and stopping data transactions to

(cont.)

## System Block Diagram

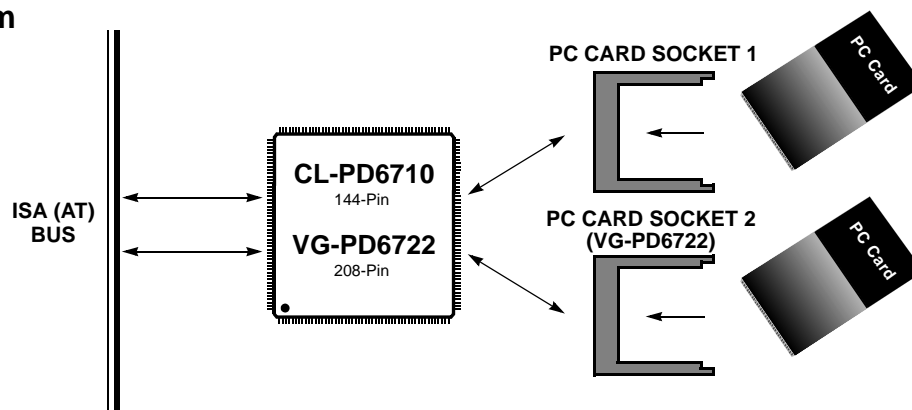



**OVERVIEW** (cont.)

the PC Cards; and a hardware-controlled Super Suspend mode, which reduces current to the  $\mu\text{A}$  range.

Personal computer applications typically access PC Cards through a third-party socket/card-services software interface. To assure full compatibility with industry-standard socket/card-services software and PC Card applications, the register set in the CL-PD6710

and VG-PD6722 is a superset of the Intel® 82365SL register set.

The chips provide fully buffered PC Card interfaces, meaning that no external logic is required for buffering signals to/from the interface, and power consumption can be controlled by limiting signal transitions on the PC Card bus.

**Notebook Computer Design Priorities**

n Small Form Factor

n Minimum Power Consumption

n High Performance

n Compatibility

**Supporting Features**

- r Single-chip solutions
- r No external buffers for host or socket
- r Efficient board layout
- r Automatic Low-Power Dynamic mode
- r Hardware- and software-controlled Suspend modes
- r Mixed-voltage operation
- r Write cache
- r Programmable timing supports more cards, faster reads and writes
- r Automatic bus sizing for 8- or 16-bit
- r DMA available with the VG-PD6722
- r Compliant with PC Card Standard, PCMCIA 2.1, and JEIDA 4.1
- r 82365SL A-step register-compatible, ExCA™-compatible

**Host Adapter Form Factor**



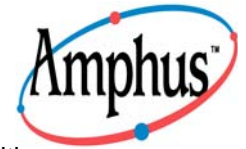

**Table of Contents**

<b>1. GENERAL CONVENTIONS.....7</b>	7.6 Card I/O Map 0–1 Offset Address Low .....52
<b>2. PIN INFORMATION .....8</b>	7.7 Card I/O Map 0–1 Offset Address High .....52
2.1 Pin Diagrams ..... 9	<b>8. MEMORY WINDOW MAPPING</b>
2.2 Pin Description Conventions..... 11	<b>REGISTERS .....53</b>
2.3 Pin Descriptions..... 12	8.1 System Memory Map 0–4 Start Address
2.4 Power-On Configuration Summary..... 21	Low .....53
<b>3. INTRODUCTION.....22</b>	8.2 System Memory Map 0–4 Start Address
3.1 System Architecture.....22	High..... 54
3.1.1 PC Card Basics ..... 22	8.3 System Memory Map 0–4 End Address
3.1.2 VG-PD67XX Windowing Capabilities ..... 22	Low ..... 54
3.1.3 VG-PD67XX Functional Blocks ..... 25	8.4 System Memory Map 0–4 End Address
3.1.4 Interrupts ..... 25	High.....55
3.1.5 Alternate Functions of Interrupt Pins ..... 26	8.5 Card Memory Map 0–4 Offset Address
3.1.6 General-Purpose Strobe Feature ..... 26	Low .....56
3.1.7 Voltage Sense Pins ..... 27	8.6 Card Memory Map 0–4 Offset Address
3.1.8 VG-PD67XX Power Management ..... 27	High.....56
3.1.9 Socket Power Management Features ..... 28	<b>9. EXTENSION REGISTERS .....58</b>
3.1.10 Write FIFO ..... 29	9.1 Misc Control 1 .....58
3.1.11 Bus Sizing..... 29	9.2 FIFO Control ..... 60
3.1.12 Programmable PC Card Timing..... 29	9.3 Misc Control 2 ..... 61
3.1.13 ATA Mode Operation ..... 29	9.4 Chip Information..... 63
3.1.14 DMA Mode Operation for	9.5 ATA Control ..... 64
the VG-PD6722 ..... 30	9.6 Extended Index ..... 65
3.1.15 Selective Data Drive for I/O Windows..... 30	9.7 Extended Data ..... 65
3.2 Host Access to Registers..... 30	9.7.1 Data Mask 0–1..... 66
3.3 Power-On Setup ..... 31	9.7.2 Extension Control 1 (VG-PD6722 only,
<b>4. REGISTER DESCRIPTION</b>	formerly DMA Control) ..... 66
<b>CONVENTIONS..... 32</b>	9.7.3 Maximum DMA Acknowledge Delay (VG-
<b>5. OPERATION REGISTERS.....33</b>	PD6722 only) ..... 67
5.1 Index ..... 33	9.7.4 External Data (VG-PD6722 only, Socket A,
5.2 Data ..... 36	Index 2Fh) ..... 69
<b>6. CHIP CONTROL REGISTERS.....37</b>	9.7.5 External Data (VG-PD6722 only, Socket A,
6.1 Chip Revision..... 37	Index 6Fh) ..... 70
6.2 Interface Status ..... 38	9.7.6 Extension Control 2 (VG-PD6722 only) ..... 71
6.3 Power Control ..... 40	<b>10. TIMING REGISTERS ..... 72</b>
6.4 Interrupt and General Control ..... 42	10.1 Setup Timing 0–1 ..... 72
6.5 Card Status Change..... 44	10.2 Command Timing 0–1 ..... 73
6.6 Management Interrupt Configuration ..... 45	10.3 Recovery Timing 0–1 ..... 74
6.7 Mapping Enable..... 47	<b>11. ATA MODE OPERATION ..... 75</b>
<b>7. I/O WINDOW MAPPING</b>	<b>12. USING GPSTB PINS FOR EXTERNAL</b>
<b>REGISTERS..... 49</b>	<b>PORT CONTROL (VG-PD6722 only) .77</b>
7.1 I/O Window Control..... 49	12.1 Control of GPSTB Pins ..... 77
7.2 System I/O Map 0–1 Start Address Low ..... 50	12.2 Example Implementations of GPSTB-Controlled
7.3 System I/O Map 0–1 Start Address High ..... 50	Read and Write Ports..... 79
7.4 System I/O Map 0–1 End Address Low ..... 51	12.3 GPSTB in Suspend Mode..... 80
7.5 System I/O Map 0–1 End Address High ..... 51	



<b>13. VS1# AND VS2# VOLTAGE DETECTION</b>	<b>81</b>	15.3.4 General-Purpose Strobe Timing (VG-PD6722 only)	96
<b>14. DMA OPERATION (VG-PD6722 only)</b>	<b>83</b>	15.3.5 Input Clock Specification	97
14.1 DMA Capabilities of the VG-PD6722	83	15.3.6 PC Card Bus Timing Calculations	98
14.2 DMA-Type PC Card Cycles	83	15.3.7 PC Card Socket Timing	99
14.3 ISA Bus DMA Handshake Signal	84	<b>16. PACKAGE SPECIFICATIONS</b>	<b>110</b>
14.4 Configuring the VG-PD6722 Registers for a DMA Transfer	84	16.1 144-Pin VQFP Package	110
14.4.1 Programming the DMA Request Pin from the Card	85	16.2 208-Pin PQFP Package	111
14.4.2 Configuring the Socket Interface for I/O	86	16.3 208-Pin VQFP Package	112
14.4.3 Preventing Dual Interpretation of DMA Handshake Signals	86	<b>17. ORDERING INFORMATION EXAMPLE</b>	<b>113</b>
14.4.4 Turning On DMA System	86	<b>A. Register Summary Tables</b>	<b>114</b>
14.5 The DMA Transfer Process	86	B.1 Operation Registers	114
14.6 Terminal Count to Card at Conclusion of Transfer	86	B.2 Chip Control Registers	114
		B.3 I/O Window Mapping Registers	116
		B.4 Memory Window Mapping Registers	117
		B.5 Extension Registers	118
		B.6 Timing Registers	121
<b>15. ELECTRICAL SPECIFICATIONS</b>	<b>87</b>	<b>INDEX</b>	<b>122</b>
15.1 Absolute Maximum Ratings	87		
15.2 DC Specifications	87		
15.3 AC Timing Specifications	91		
15.3.1 ISA Bus Timing	92		
15.3.2 Reset Timing	94		
15.3.3 System Interrupt Timing	95		



## Document Revision History

### Version 3.1

Following are major changes between September 1995 and May 1997 versions of this data sheet:

#### General

The CL-PD6710 replaces the CL-PD6712, which was taken out of production. This change is reflected throughout this data sheet. Major differences of the CL-PD6710 from the CL-PD6712 include:

The CL-PD6710 does not support DMA.  
Only a single voltage sense pin is available.  
GPSTB functionality is not supported.

References to the CL-PD6720 were removed. References to the VG-PD672X were replaced with VG-PD6722.

For the CL-PD6710, two pin names were changed from the CL-PD6712 to reflect their different functionality:

VS1#/A\_GPSTB is now 5V\_DET.  
VS2#/B\_GPSTB is now a no connect.

#### Section

- 2.2** The General-Purpose Strobe/Voltage Sense pins in the CL-PD6712 (VS1#/A\_GPSTB and VS2#/B\_GPSTB) were replaced by the 5V\_DET in the CL-PD6710.
- 5.1** The Extended Index and Extended Data registers (Scratchpad, Data Mask 0, Data Mask 1, Extension Control 1, Maximum DMA Acknowledge Delay, Reserved, External Data, and Extension Control 2) are only available on the VG-PD6722, not on the CL-PD6710.
- 13** Voltage detection on the CL-PD6710 is provided by the 5V\_DET pin.

### Version 3.0

Following are major changes between July 1994 and September 1995 versions of this data sheet:

#### General

A new chip was added: the CL-PD6712, which replaces the CL-PD6710.

Extended register set was expanded.

208-pin VQFP package option was added for the CL-PD6720 and VG-PD6722.

Some windowing register names were changed to specify either card or system.

References to PCMCIA card were changed to PC Card.

The chips are compatible with PC Card Standard, as R2 PC Card controllers.

For the CL-PD6712, two pin names are different than the CL-PD6710 to reflect new functionality:

5V\_DET became VS1#/A\_GPSTB  
N.C./RESERVED became VS2#/B\_GPSTB

For the VG-PD672X, two pin names were changed to reflect new functionality:

A\_5V\_DET became A\_GPSTB  
B\_5V\_DET became B\_GPSTB

For the VG-PD67XX, four pin names were changed to reflect their full functionality:

IRQ12 became IRQ12/LED\_OUT\*  
IRQ15 became IRQ15/RI\_OUT\*  
BVD1/-STSCHG became BVD1/-STSCHG/-RI  
BVD2/-SPKR became BVD2/-SPKR/-LED

For the VG-PD67XX, two pin names were changed to match other PC Card products:

SLOT\_VCC became SOCKET\_VCC  
VDD became CORE\_VDD

#### Section

- 2.2** I/O type codes changed.
- 2.3** Table columns rearranged, power control pins placed in their own table.  
Table added for general-purpose strobe / voltage sense pins.
  - 3.1.2** Windowing figures added.
  - 3.1.3** Functional block figure added.
  - 3.1.5** More information about LED\_OUT\*, RI\_OUT\*, DACK\*, and DRQ alternate functions of interrupt pins added.
  - 3.1.6** Section on general-purpose strobe added.
  - 3.1.7** Section on voltage sense added.
- 3.2** Sample code for accessing registers added.
- 4** Read/Write Convention table added.
- 6.3** Auto-Power bit description changed.
- 6.4** IRQ Level bits name changed to Card IRQ Select.
- 6.6** Management IRQ bits name changed to Management IRQ Select.
- 9.1** 5V Detect (bit 0 of index 16h) is now Reserved.
- 9.4** Chip Identification (bits 7:6 of index 1Fh) is now named Host-Adapter Identification.
- 9.7** **External Data** and **Extension Control 2** registers added.  
LED Activity Enable bit added to **Extension Control 1** register. Auto Power Clear bit name changed to Auto Power Clear Disable.



- 10 '11' value of Prescaler Select bits of timing registers changed to 8192.  
For Command Multiplier Value bits, order of reset states for Timing sets 0 and 1 switched to show reset state for Timing set 0 first.  
**Recovery Timing** register reset value changed to 03h to allow additional I/O cycle recovery time of systems using 'DX/4 processors.
- 11 ATA information is now in an application note.
- 12 General-purpose strobe chapter added.
- 13 Voltage sense chapter added.
- 15.1 Allowable voltage on any pin increased to  $\pm 0.5$  V greater than voltage of +5V pin.
- 15.3 Table 15-7: values for t2, t2a, t10, t13, and t18 of ISA bus timing table changed.  
Table 15-9: Pulse mode interrupt timing added.  
Table 15-10: General-purpose strobe timing added.  
Table 15-12: values of t5 and t6 of memory read/write timing table changed.  
Table 15-13: -WAIT timing values added to word I/O read/write timing.  
Table 15-17 and 15-18: DMA read and write cycle timing tables expanded.
- 16 208-pin VQFP package added.

### Version 2.5

Following are major changes between October 1993 and July 1994 versions of this data sheet:

#### General

An extension register and two bits have been added to the VG-PD6722 register set.

#### Section

- 1.2 Description for bits labeled Reserved, Compatibility, 0 or 1, and Scratchpad have been clarified.
- 5.2 In the table for "Bits 1-0: Battery Voltage Detect", the column headings for bit 1 and bit 0 were reversed, and have been corrected.
- 5-7 Bits 6, 3, and 2 (index 2h), bits 6 and 2 (index 7h), and bit 6 (index 11h, 19h, 21h, 29h, 31h) have been relabeled Compatibility bits.
- 6.6 Bit 0 (index 36h, 38h) has been relabeled 0.
- 8.4 Bit 1 (index 1Fh) has been changed to be a part of the VG-PD67XX Revision Level field. Bit 0 has been relabeled Reserved.
- 8.7 Two bits, Auto-Power Clear and  $V_{CC}$  Power Lock, and a register, **Maximum DMA Acknowledge Delay**, have been added to descriptions of the VG-PD6722 registers. The **DMA Control** register was renamed **Extension Control 1**. The Disable

- Socket Pull-Ups bit was renamed Pull-Up Control.
- 11.3 References to -WE and -OE in the last paragraph have been corrected.
- 11.4.1 The table on DMA signal usage and Figure 11-2 have been slightly modified.
- 13 The 144- and 208-pin package drawings have been updated.

### Version 2

Following are major changes between January 1993 and October 1993 versions of this data sheet:

#### General

- A new chip was added: the VG-PD6722.
- The VG-PD672X packaging name was changed to PQFP; the physical package is the same.
- The chips are also compatible with PCMCIA 2.1.

#### Section

- 2.2 SPKR\_OUT\*/CSEL pin description in Table 2-1 was changed from TO-PU type to IO-PU type. Addition of the VG-PD6722 chip changed description in Tables 2-1 and 2-2 of the following pins: IRQ9, IRQ10, -VPP\_VALID, -REG, -OE, -WE, WP/-IOIS16, -INPACK, and BVD2/-SPKR.
- 3.1 The typical power consumption values in Table 3-1 were updated (reduced) to more closely reflect expected values.  
Sections 3.1.10 and 3.1.11 are new sections describing the VG-PD6722.
- 5-9 Many indications of Constant bits in registers were changed from "0" to "Scratch Bit".
- 5 In the Card Status Change register, the Battery Dead/STSCHG Enable bit name was renamed Battery Dead Or Status Change Enable.
- 8 The Misc Control 2 register bit 6 is not reserved on the VG-PD6722. Its functionality is described. Sections 8.6 and 8.7 were added to describe VG-PD6722-specific registers.
- 9 The Setup, Command, and Recovery field names were altered. The default state for the Command Multiplier Value field was corrected. The timing formulas for all three timing register sets were reformatted. The timing with '11' values selected on the Prescaler Select field calculate differently.
- 11 This new chapter describes DMA on the VG-PD6722.
- 12 Extensive changes were made throughout this chapter. Please review carefully.









## 1. GENERAL CONVENTIONS

The following general conventions apply to this document.

Throughout this document, *VG-PD67XX* means CL-PD6710 and VG-PD6722.

Bits within words and words within various memory spaces are generally numbered with a 0 (zero) as the least-significant bit or word. For example, the least-significant bit of a byte is bit 0, while the most-significant bit is bit 7.

In addition, number ranges for bit fields and words are presented with the most-significant value first. Thus, when discussing a bit field within a register, the bit number of the most-significant bit is written first, followed by a colon (:) and then the bit number of the least-significant bit; as in, bits 7:0.

In this document, the names of the VG-PD67XX internal registers are boldfaced. For example, **Chip Revision** and **Power Control** are register names. The names of bit fields are written with initial uppercase letters. For example, Card Power On and Battery Voltage Detect are bit field names.

### *Numbers and Units*

The unit *Kbyte* designates 1024 bytes ( $2^{10}$ ). The unit *Mbyte* designates 1,048,576 bytes ( $2^{20}$ ). The unit *Gbyte* designates 1,073,741,824 bytes ( $2^{30}$ ). The unit *Hz* designates hertz. The unit *kHz* designates 1000 Hz. The unit *MHz* designates 1,000,000 Hz. The unit *ms* designates millisecond. The unit  $\mu\text{s}$  designates microsecond. The unit *ns* designates nanosecond. The unit *mA* designates milliampere. The unit *V* immediately following a number designates volt.

Hexadecimal numbers are presented with all letters in uppercase and a lowercase *h* appended. For example, *14h* and *03CAh* are hexadecimal numbers.

Binary numbers are enclosed in single quotation marks when in text. For example, '11' is a binary number.

Numbers not appended with an *h* nor enclosed by single quotation marks are decimal.

In addition, a capital letter *X* is used within numbers to indicate digits ignored by the VG-PD67XX within the current context. For example, '101XX01' is a binary number with bits 3:2 ignored.



## **2. PIN INFORMATION**

The CL-PD6710 is available in a 144-pin VQFP (very tight-pitch quad flat pack) component package and the VG-PD6722 is available in either a 208-pin PQFP (plastic quad flat pack) component package or a 208-pin VQFP component package. The interface pins can be divided into five groups:

- | ISA bus interface pins
- | PC Card socket interface pins (one or two sets)
- | General-purpose strobe / voltage sense pins
- | Power control pins
- | Power and ground pins

Refer to Figure 2-1 for the CL-PD6710 and Figure 2-2 for the VG-PD6722 pin diagrams. The pin assignments for the groups of interface pins are shown in Table 2-1 through Table 2-5.



**2.1 Pin Diagrams**

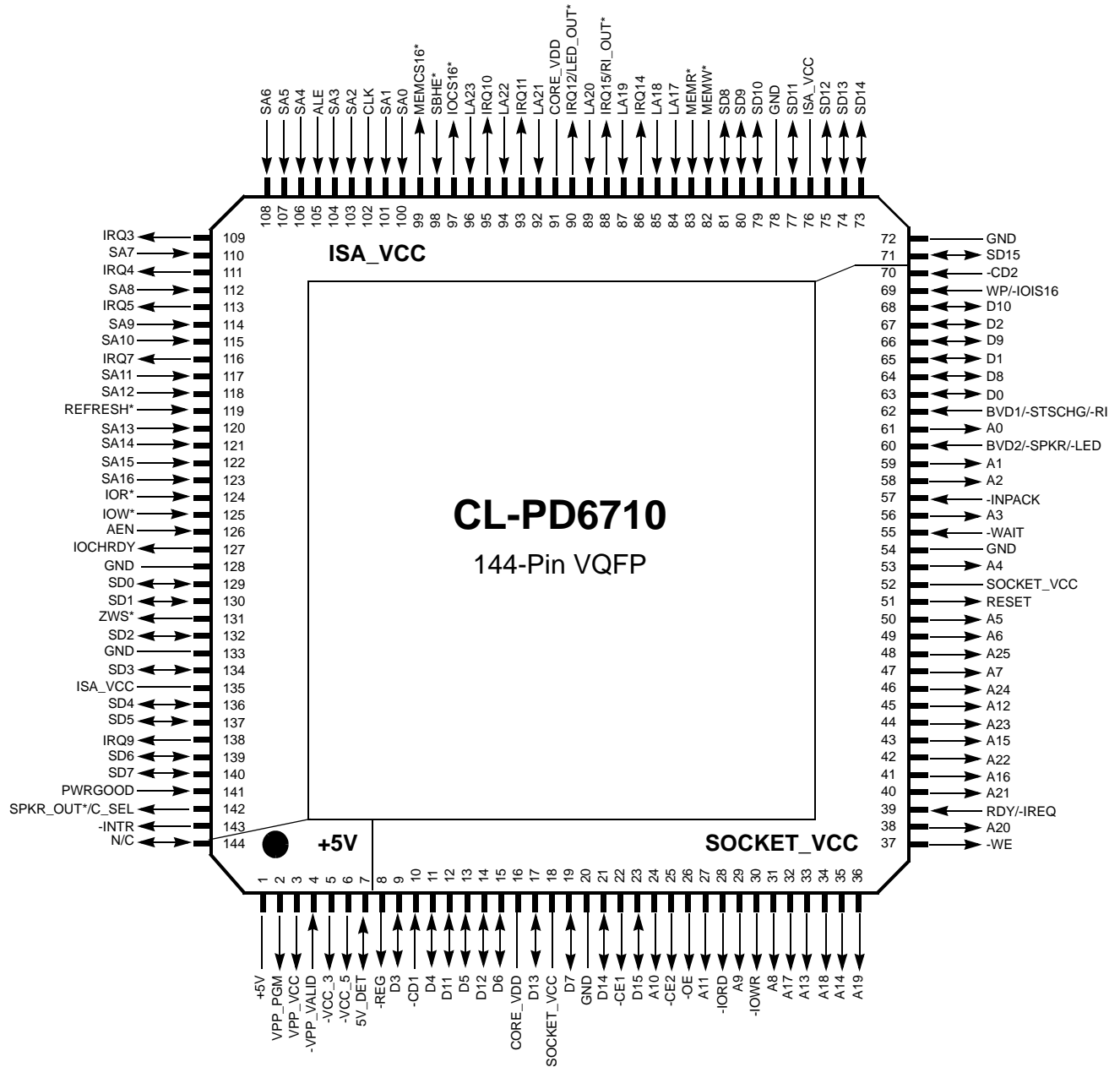

**Figure 2-1. CL-PD6710 Pin Diagram**

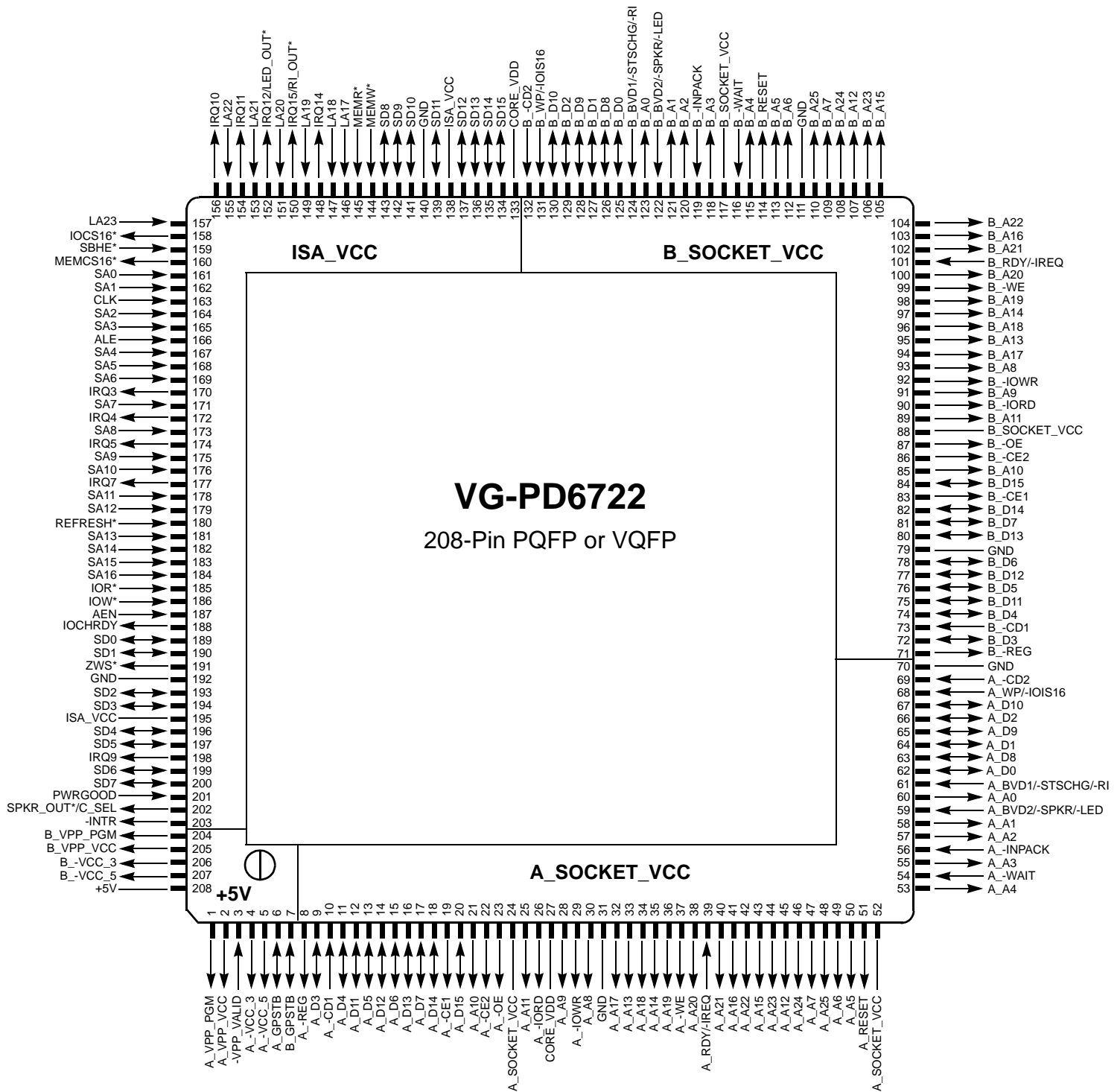

Figure 2-2. VG-PD6722 Pin Diagram



## 2.2 Pin Description Conventions

The following conventions apply to the pin description tables in Section 2.3:

- 1 A dash (-) at the beginning of a pin name indicates an active-low signal for the PC Card bus.
- 1 An asterisk (\*) at the end of a pin name indicates an active-low signal for the ISA bus or that is a general interface for the VG-PD67XX.
- 1 Pins marked with a dagger (†) in the pin description tables can be switched between CMOS and TTL input levels when CORE\_VDD is powered at 5 volts. All other pins use CMOS input levels when CORE\_VDD is powered at 5 volts and TTL input levels when powered at 3.3 volts.
- 1 A pin name ending in bracketed digits separated by a colon [n:n] indicates a multi-pin bus.
- 1 The pin number (Pin Number) column indicates the package pin that carries the listed signal. Note that multi-pin buses are listed with the first pin number corresponding to the most-significant bit of the bus. For example, pin numbers 123:120, 118, 117, 115, 114, 112, 110, 108:106, 104, 103, 101, and 100 are associated with ISA Bus Address Input and Data Input/Output pins SA[16:0] and indicate that:
  - SA16 is pin 123
  - SA15 is pin 122
  - SA0 is pin 100
- 1 The quantity (Qty.) column indicates the number of pins used (per socket where applicable).
- 1 The I/O-type code (I/O) column indicates the input and output configurations of the pins on the VG-PD67XX. The possible types are defined below.
- 1 The power-type code (Pwr.) column indicates the output drive power source for an output pin or the pull-up power source for an input pin on the VG-PD67XX. The possible types are defined below.

I/O Type	Description
I	Input pin
O	Constant-driven output pin
I/O	Input/output pin
O-OD	Open-drain output pin
O-TS	Tristate output pin
-PU	An internal pull-up resistor is present
GND	Ground pin
PWR	Power pin

Power Type	Output or Pull-up Power Source
1	+5V: powered from a 5.0-volt power supply in most systems (see description of +5V pin in Table 2-5)
2	A_SOCKET_VCC: powered from the Socket A V <sub>CC</sub> supply connecting to PC Card pins 17 and 51 of Socket A
3	B_SOCKET_VCC: powered from the Socket B V <sub>CC</sub> supply connecting to PC Card pins 17 and 51 of Socket B
4	ISA_VCC: powered from the ISA bus power supply
5	CORE_VDD: usually powered from the lowest available power supply for lowest power consumption, which in most systems is 3.3 volts

**NOTE:** All pin inputs are referenced to CORE\_VDD, independent of their output supply voltage.

- 1 The drive-type (Drive) column describes the output drive-type of the pin (see DC specifications in Chapter 14 for more information). Note that the drive type listed for an input-only (I) pin is not applicable (-).



## 2.3 Pin Descriptions

**Table 2-1. ISA Bus Interface Pins**

Pin Name	Description	Pin Number		Qty.	I/O	Pwr.	Drive
		CL-PD6710	VG-PD6722				
LA[23:17]	<b>ISA Bus Address Input:</b> Connect to ISA signals LA[23:17] or, for systems limited to 1-Mbyte address space, tie ALE high, ground LA[23:20] and connect LA[19:17] to ISA signals SA[19:17].	96, 94, 92, 89, 87, 85, 84	157, 155, 153, 151, 149, 147, 146	7	I	4	–
SA[16:0]	<b>ISA Bus Address Input:</b> Connect to ISA signals SA[16:0].	123:120, 118, 117, 115, 114, 112, 110, 108:106, 104, 103, 101, 100	184:181, 179, 178, 176, 175, 173, 171, 169:167, 165, 164, 162, 161	17	I	4	–
SD[15:0]	<b>ISA Bus Data Input/Output:</b> These pins are used to transfer data during a memory or I/O cycle. Connect to ISA signals SD[15:0]. For 8-bit system buses, leave SD[15:8] unconnected.	71, 73–75, 77, 79–81, 140, 139, 137, 136, 134, 132, 130, 129	134–137, 139, 141–143, 200, 199, 197, 196, 194, 193, 190, 189	16	I/O	4	12 mA
SBHE*	<b>Byte High Enable:</b> This input is used in conjunction with SA[0] to specify the width and alignment of a data transfer. Connect to ISA signal SBHE*. For 8-bit system buses, pull up connect to ISA_VCC supply.	98	159	1	I	4	–
IOR*	<b>I/O Read:</b> This input indicates that a host I/O read cycle is occurring. Connect to ISA signal IOR*.	124	185	1	I	4	–
IOW*	<b>I/O Write:</b> This input indicates that a host I/O write cycle is occurring. Connect to ISA signal IOW*.	125	186	1	I	4	–
MEMR*	<b>Memory Read:</b> This input indicates that a host memory read cycle is occurring. Connect to ISA signal MEMR*.	83	145	1	I	4	–
MEMW*	<b>Memory Write:</b> This input indicates that a host memory write cycle is occurring. Connect to ISA signal MEMW*.	82	144	1	I	4	–
REFRESH*	<b>Refresh:</b> This input indicates a memory refresh cycle is occurring and will cause the VG-PD67XX to ignore memory accesses on the bus. Connect to ISA signal REFRESH*.	119	180	1	I	4	–
ALE	<b>Address Latch Enable:</b> A high on this input indicates a valid memory address on the LA[23:17] bus lines. Connect to ISA signal BALE.	105	166	1	I	4	–
PWRGOOD	<b>Power Good:</b> The VG-PD67XX will be reset when the POWERGOOD input is low. Connect to the POWERGOOD signal from the system power supply; or, if not available, connect to inverted RESETDRV signal from ISA bus.	141	201	1	I	4	–



**Table 2-1. ISA Bus Interface Pins (cont.)**

Pin Name	Description	Pin Number		Qty.	I/O	Pwr.	Drive
		CL-PD6710	VG-PD6722				
AEN	<p><b>Address Enable:</b> This is an input from the host CPU bus signal that distinguishes between DMA and non-DMA bus cycles. This input should be high for a DMA cycle and will cause the VG-PD67XX to ignore IOR* and IOW* except when a VG-PD6722 is configured for DMA and its DREQ (IRQ10) and DACK* (IRQ9) signals are active. Connect to ISA signal AEN.</p> <p>When VG-PD67XX is in Suspend mode (see Misc Control 2, bit 2 on page 53), pull this input high during system power-down for lowest power consumption.</p>	126	187	1	I	4	–
MEMCS16*	<p><b>Memory Select 16:</b> This output is an acknowledge of 16-bit-wide access support and is generated by the VG-PD67XX when a valid 16-bit-word-accessible memory address has been decoded. Connect to ISA signal MEMCS16*.</p>	99	160	1	O-OD	4	16 mA
IOCS16*	<p><b>I/O Select 16:</b> This output is an acknowledge for 16-bit-wide access support and is generated by the VG-PD67XX when a valid 16-bit word accessible I/O address has been decoded. Connect to ISA signal IOCS16*.</p>	97	158	1	O-OD	4	16 mA
IOCHRDY	<p><b>I/O Channel Ready:</b> This output is driven low by the VG-PD67XX to lengthen host cycles. Connect to the ISA bus IOCHRDY signal.</p>	127	188	1	O-TS	4	16 mA
IRQ[14, 11, 7, 5:3]	<p><b>Interrupt Request:</b> These outputs indicate programmable interrupt requests generated from any of a number of card actions. Although there is no specific mapping requirement for connecting interrupt lines from the VG-PD67XX to the system, a common use is to connect these pins to the corresponding ISA signal names in the system.</p>	86, 93, 116, 113, 111, 109	148, 154, 177, 174, 172, 170	6	O-TS	4	2 mA
IRQ9	<p><b>Interrupt Request 9:</b> In default mode this output indicates an interrupt request from one of the cards.</p> <p>When the VG-PD6722 is in DMA mode (see Misc Control 2, bit 6), IRQ9 becomes an input and is connected to the ISA bus DACK* line corresponding to the ISA bus DREQ line that the IRQ10 pin is connected to. In DMA mode this signal is active-low.</p>	138	198	1	I/O-TS	4	2 mA
IRQ10	<p><b>Interrupt Request 10:</b> In IRQ mode this output indicates an interrupt request from one of the cards.</p> <p>When the VG-PD6722 is in DMA mode (see Misc Control 2, bit 6), IRQ10 is the DREQ to be connected to DREQ0, 1, 2, 3, 5, 6, 7 of the ISA bus. In DMA mode this signal is active-high.</p>	95	156	1	O-TS	4	2 mA



**Table 2-1. ISA Bus Interface Pins** (cont.)

Pin Name	Description	Pin Number		Qty.	I/O	Pwr.	Drive
		CL-PD6710	VG-PD6722				
IRQ12/ LED_OUT*	<b>Interrupt Request 12 / LED Output:</b> In default IRQ mode this output indicates an interrupt request from one of the cards, and is connected to the ISA bus IRQ12 signal. When the Drive LED Enable bit (see page 53) is set, this output becomes an open-drain driver for a disk-active LED (see <b>ATA Control</b> register bit 1) or PC Card activity LED (see <b>Extension Control 1</b> register bit 2).	90	152	1	O- TS or O- OD	4	12 mA
IRQ15/ RI_OUT*	<b>Interrupt Request 15 / Ring Indicate Output:</b> In IRQ mode this output indicates an interrupt request from one of the cards. When the IRQ15/RI_OUT* Is RI Out bit (see page 54) is set to '1', this output is the -RI signal from the corresponding PC Card.	88	150	1	O- TS	4	2 mA
-INTR	<b>Interrupt:</b> This output indicates a management interrupt. This should be connected to the system processor's SMI or NMI interrupt input, depending on the type of processor used.	143	203	1	O- TS	4	2 mA
ZWS*	<b>Zero Wait State:</b> This output is connected to the ISA ZWS (OWS) signal. It is driven low by the VG-PD67XX when it is able to complete the current memory access cycle in zero wait states.	131	191	1	O- OD	4	16 mA





Table 2-1. ISA Bus Interface Pins (cont.)

Pin Name	Description	Pin Number		Qty.	I/O	Pwr.	Drive
		CL-PD6710	VG-PD6722				
SPKR_OUT*/ C_SEL	<p><b>Speaker Out / Chip Select:</b> This I/O pin can be used as a digital output to a speaker to allow a system to support a PC Card's -SPKR pin for fax/modem/voice and audio. During reset this pin also serves as a chip-configuration input.</p> <p>If the level on this pin is low when PWRGOOD rises, the CL-PD6710 is configured to support cards as a PC Card Socket 2 device, and the VG-PD6722 is configured to support cards as PC Card Socket 2 and Socket 3 devices.</p> <p>If the level on this pin is high when PWRGOOD rises, the CL-PD6710 is configured to support cards as a PC Card Socket 0 device, and the VG-PD6722 is configured to support cards as PC Card Socket 0 and Socket 1 devices.</p> <p>This pin is internally pulled up during reset so that default configuration of the chip as a Socket 0 (and Socket 1 for VG-PD6722) is facilitated. Adhere to the minimum pulse-width timing specification for PWRGOOD to allow the internal pull-up to operate and ensure the default configuration. Refer to the Socket Index field on page 25 for more information on chip configuration.</p> <p>After reset operations have completed, this pin defaults to high-impedance, and can then be enabled as a totem-pole speaker output by the setting of a card socket's Speaker Enable bit (<b>Misc Control 1</b> register, bit 4). This output then becomes the negative polarity XOR of each socket's BVD2/-SPKR/-LED input that has its Speaker Enable bit set. For a description of socket index values, refer to Section 4.1.</p>	142	202	1	I/O- PU	4	12 mA
CLK	<p><b>Clock:</b> This input is connected to the ISA bus OSC signal. A 14.318-MHz signal is used to derive the internal 25-MHz clock used for all socket timing. Alternately, a 25-MHz clock source can be directly connected and the internal synthesizer bypassed.</p>	102	163	1	I	4	-
-VPP_VALID	<p>In default mode this is a status input that can be used by software as an indication that the V<sub>PP</sub> power supply is stable.</p> <p>When the VG-PD6722 is in DMA mode (see Misc Control 2, bit 6), this input is connected to the TC (Terminal Count) signal of the ISA bus. In DMA mode, this signal is active-high.</p>	4	3	1	I	1	-
ISA_VCC	<p><b>System Bus V<sub>CC</sub>:</b> This supply pin can be set to 3.3 or 5.0 V. The ISA Bus Interface pin group (this table) operates at the voltage applied to this pin independent of the voltage applied to other pin groups.</p>	76, 135	138, 195	2	PWR	-	-



**Table 2-2. Socket Interface Pins**

Pin Name <sup>1</sup>	Description <sup>2</sup>	Pin Number		Qty	I/O	Pwr.	Drive	
		CL-PD6710	VG-PD6722					
			Socket A					Socket B
-REG	<p><b>Register Access:</b> In Memory Card Interface mode, this output chooses between attribute and common memory. In I/O Card Interface mode for non-DMA transfers, this signal is active (low).</p> <p>For DMA cycles on the VG-PD6722 to a DMA-capable card, -REG is inactive during I/O cycles to indicate a DMA cycle to or from the PC Card.</p> <p>In ATA mode, this signal is always inactive.</p>	8	8	71	1	O-TS	2 or 3	2 mA
A[25:0]	PC Card socket address outputs.	48, 46, 44, 42, 40, 38, 36, 34, 32, 41, 43, 35, 33, 45, 27, 24, 29, 31, 47, 49, 50, 53, 56, 58, 59, 61	48, 46, 44, 42, 40, 38, 36, 34, 32, 41, 43, 35, 33, 45, 25, 21, 28, 30, 47, 49, 50, 53, 55, 57, 58, 60	110, 108, 106, 104, 102, 100, 98, 96, 94, 103, 105, 97, 95, 107, 89, 85, 91, 93, 109, 112, 113, 115, 118, 120, 121, 123	26	O-TS	2 or 3	2 mA
D[15:0] †	PC Card socket data I/O signals.	23, 21, 17, 14, 12, 68, 66, 64, 19, 15, 13, 11, 9, 67, 65, 63	20, 18, 16, 14, 12, 67, 65, 63, 17, 15, 13, 11, 9, 66, 64, 62	84, 82, 80, 77, 75, 130, 128, 126, 81, 78, 76, 74, 72, 129, 127, 125	16	I/O	2 or 3	2 mA
-OE	<p><b>Output Enable:</b> For non-DMA transfers, this output goes active (low) to indicate a memory read from the socket.</p> <p>During a DMA write (when -IORD is active) this output goes low if the ISA output TC is active (high), indicating to the card that the system's terminal count signal is active. During DMA reads (when -IOWR is active), this output remains high.</p>	26	23	87	1	O-TS	2 or 3	2 mA

<sup>1</sup> To differentiate the sockets, all VG-PD6722 pin names have either A\_ or B\_ prepended to the pin names indicated. For example, A\_A[25:0] and B\_A[25:0] are the independent address buses to the sockets.

<sup>2</sup> When a socket is configured as an ATA drive interface, socket interface pin functions change. See Table 10-1 on page 67.



Table 2-2. Socket Interface Pins (cont.)

Pin Name <sup>1</sup>	Description <sup>2</sup>	Pin Number			Qty	I/O	Pwr.	Drive
		CL-PD6710	VG-PD6722					
			Socket A	Socket B				
-WE	<p><b>Write Enable:</b> For non-DMA transfers, this signal goes active (low) to indicate a memory write to the socket.</p> <p>During a DMA read (when -IOWR is active), this signal goes low if the ISA output TC is active (high), indicating to the card that the system's terminal count signal is active. During DMA writes (when -IORD is active), this output remains high.</p>	37	37	99	1	O-TS	2 or 3	2 mA
-IORD	<p><b>I/O Read:</b> This output is driven low for I/O reads from the socket.</p>	28	26	90	1	O-TS	2 or 3	2 mA
-IOWR	<p><b>I/O Write:</b> This output is driven low for I/O writes to the socket.</p>	30	29	92	1	O-TS	2 or 3	2 mA
WP/ -IOIS16 †	<p><b>Write Protect / I/O Is 16-Bit:</b> In Memory Card Interface mode (Interrupt and General Control register, bit 5 is equal to '0'), this input is the status of the PC card write protect switch.</p> <p>In I/O Card Interface mode, a low on this input indicates that the I/O address being accessed is capable of 16-bit operation.</p> <p>In DMA mode, this pin can be programmed as the -DREQ input from a DMA-capable PC Card.</p>	69	68	131	1	I-PU	2 or 3	–
-INPACK †	<p><b>Input Acknowledge:</b> This input indicates to the VG-PD67XX that the PC Card supports I/O access at the current address. A PC Card activates this input during IORD cycles to which the card can respond.</p> <p>In DMA mode, this pin can be programmed as the -DREQ input from a DMA-capable PC Card.</p>	57	56	119	1	I-PU	2 or 3	–
RDY/ -IREQ †	<p><b>Ready / Interrupt Request:</b> In Memory Card Interface mode, this input is readable as the status of bit 5 of the <b>Interface Status</b> register, which is used by a PC Card to signal system software of its ready or busy state.</p> <p>In I/O Card Interface mode, this active-low input indicates an interrupt request.</p>	39	39	101	1	I-PU	2 or 3	–

<sup>1</sup> To differentiate the sockets, all VG-PD6722 pin names have either A\_ or B\_ prepended to the pin names indicated. For example, A\_A[25:0] and B\_A[25:0] are the independent address buses to the sockets.

<sup>2</sup> When a socket is configured as an ATA drive interface, socket interface pin functions change. See Table 10-1 on page 67.



**Table 2-2. Socket Interface Pins (cont.)**

Pin Name <sup>1</sup>	Description <sup>2</sup>	Pin Number			Qty	I/O	Pwr.	Drive
		CL-PD6710	VG-PD6722					
			Socket A	Socket B				
-WAIT †	<b>Wait:</b> This input indicates to the VG-PD67XX that the current card access cycle is to be extended until this signal becomes inactive (high).	55	54	116	1	I-PU	2 or 3	–
-CD[2:1]	<b>Card Detect:</b> These inputs indicate to the VG-PD67XX the presence of a card in the socket. They are pulled high internally in the chip.	70, 10	69, 10	132, 73	2	I-PU	1	–
-CE[2:1]	<b>Card Enable:</b> These outputs are driven low by the VG-PD67XX during card access cycles to control byte/word card access. -CE1 enables even-numbered address bytes and -CE2 enables odd-numbered address bytes. When configured for 8-bit cards, only -CE1 will be active and A0 will be set to '1' for odd-byte accesses.	25, 22	22, 19	86, 83	2	O-TS	2 or 3	2 mA
RESET	<b>Reset:</b> This output will be high to reset the card and low for normal operation. To reduce power consumption of idle cards and to prevent reset glitches to a card, this signal is high-impedance unless a card is fully seated in the socket and card interface signals are enabled.	51	51	114	1	O-TS	2 or 3	2 mA
BVD2/ -SPKR/ -LED †	<b>Battery Voltage Detect 2 / Speaker / LED:</b> In Memory Card Interface mode, this input serves as the BVD2 or battery warning status input.  In I/O Card Interface mode, this input can be configured as a card's -SPKR binary audio input. For disk-drive support, BVD2/-SPKR/-LED can also be configured as a drive-status LED input.  In DMA mode, this pin can be programmed as the -DREQ input from a DMA-capable PC Card.	60	59	122	1	I-PU	2 or 3	–

<sup>1</sup> To differentiate the sockets, all VG-PD6722 pin names have either A\_ or B\_ prepended to the pin names indicated. For example, A\_A[25:0] and B\_A[25:0] are the independent address buses to the sockets.

<sup>2</sup> When a socket is configured as an ATA drive interface, socket interface pin functions change. See Table 10-1 on page 67.



**Table 2-2. Socket Interface Pins (cont.)**

Pin Name <sup>1</sup>	Description <sup>2</sup>	Pin Number		Qty	I/O	Pwr.	Drive	
		CL-PD6710	VG-PD6722					
			Socket A					Socket B
BVD1/ -STSCHG/ -RI †	<b>Battery Voltage Detect 1 / Status Change / Ring Indicate:</b> In Memory Card Interface mode, this input serves as BVD1 (Battery Dead Status) input.  In I/O Card Interface mode, this input is the -STSCHG input, which indicates to the VG-PD67XX that the card's internal status has changed. In I/O Card Interface mode, this input can alternately be used as -RI ring indicate when IRQ15/RI_OUT* is configured for RI Out (see page 54).	62	61	124	1	I-PU	2 or 3	–
SOCKET_VCC	Connect these pins to the V <sub>CC</sub> supply of the socket (pins 17 and 51 of the respective PC Card socket). These pins can thus be 0, 3.3, or 5 V, depending on card presence, card type, and system configuration. The socket interface outputs (listed in this table, Table 2-2) will operate at the voltage applied to these pins, independent of the voltage applied to other VG-PD67XX pin groups.	18, 52	24, 52	88, 117	2	PWR	–	–

<sup>1</sup> To differentiate the sockets, all VG-PD6722 pin names have either A\_ or B\_ prepended to the pin names indicated. For example, A\_A[25:0] and B\_A[25:0] are the independent address buses to the sockets.

<sup>2</sup> When a socket is configured as an ATA drive interface, socket interface pin functions change. See Table 10-1 on page 67.

**Table 2-3. General-Purpose Strobe / Voltage Sense Pins**

Pin Name	Description	Pin Number		Qty	I/O	Pwr.	Drive	
		CL-PD6710	VG-PD6722					
			Socket A					Socket B
GPSTB	<b>General-Purpose Strobe:</b> Connect A_GPSTB to pin 43 and B_GPSTB to pin 57 on PC Card socket. This pin can be used with external logic to sense pins VS1 and VS2 of the socket. It is only available on the VG-PD6722. <sup>1,2</sup>	–	6	7	1	I-PU/ O-OC	1	2 mA
5V_DET	This status input is used to detect 5 V/3.3 V on PCMCIA pin 57.	7	–	–	1	I-PU	1	N/A

<sup>1</sup> General-purpose strobe controlled by 'Socket A' (index 2Eh/2Fh) **Extension Control 2** register at extended index 0Bh.

<sup>2</sup> General-purpose strobe controlled by 'Socket B' (index 6Eh/6Fh) **Extension Control 2** register at extended index 0Bh.



**Table 2-4. Power Control Pins**

Pin Name	Description	Pin Number			Qty	I/O	Pwr.	Drive
		CL-PD6710	VG-PD6722					
			Socket A	Socket B				
VPP_VCC	This output is used to enable the socket V <sub>CC</sub> supply onto the V <sub>PP</sub> pin. This pin is mutually exclusive with VPP_PGM.	3	2	205	1	O	1	12 mA
VPP_PGM	This output is used to enable the programming voltage supply onto the V <sub>PP</sub> pin. This pin is mutually exclusive with VPP_VCC.	2	1	204	1	O	1	12 mA
-VCC_3	This output is used to enable a 3.3V supply onto the V <sub>DD</sub> socket. This pin is mutually exclusive with -VCC_5.	5	4	206	1	O	1	12 mA
-VCC_5	This output is used to enable a 5V supply onto the V <sub>DD</sub> socket. This pin is mutually exclusive with -VCC_3.	6	5	207	1	O	1	12 mA

**Table 2-5. Power and Ground Pins**

Pin Name	Description	Pin Number		Qty.	I/O	Pwr.	Drive
		CL-PD6710	VG-PD6722				
+5V	This pin is connected to the system's 5-volt power supply. In systems where 5 volts is not available, this pin can be connected to the system's 3.3-volt supply (but 5-volt-only PC Cards will not be supported).	1	208	1	PWR	-	-
CORE_VDD	This pin provides power to the core circuitry of the VG-PD67XX. It can be connected to either a 3.3- or 5-volt power supply, independent of the operating voltage of other interfaces. For power conservation on a system with a 3.3-volt supply available, this pin should be connected to the 3.3-volt supply even if there is no intention of operating other interfaces on the device at less than 5 volts.	16, 91	27, 133	2	PWR	-	-
GND	All ground pins should be connected to system ground.	20, 54, 72, 78, 128, 133	31, 70, 79, 111, 140, 192	6	GND	-	-



Table 2-6 below summarizes the pin usage.

**Table 2-6. Pin Usage Summary**

Pin Group	Pin Quantity	
	CL-PD6710	VG-PD6722
ISA bus interface pins	69	69
Socket interface pins	60	120
General-purpose strobe pins	0	2
Voltage sense pins	1	0
N/C	1	0
Power control pins	4	8
Power and ground pins	9	9
<b>Total:</b>	144	208

## 2.4 Power-On Configuration Summary

On the rising edge of PWRGOOD, the VG-PD67XX latches the configuration pin SPKR\_OUT\*/C\_SEL to determine which sockets are addressed by this device. A '1' on the SPKR\_OUT\*/C\_SEL pin will cause the device to address Socket 0 (and Socket 1 for the VG-PD6722). A '0' on this pin will cause the device to address Socket 2 (and Socket 3 for the VG-PD6722).

**Table 2-7. Chip Configuration at Power-up for Socket Support**

SPKR_OUT*/C_SEL Level at Rising Edge of PWRGOOD	CL-PD6710	VG-PD6722	
	Socket Interface Support	Socket A Interface Support	Socket B Interface Support
High	PC Card Socket 0 3E0 Index 00h-3Fh	PC Card Socket 0 3E0 Index 00h-3Fh	PC Card Socket 1 3E0 Index 40h-7Fh
Low	PC Card Socket 2 3E0 Index 80h-BFh	PC Card Socket 2 3E0 Index 80h-BFh	PC Card Socket 3 3E0 Index C0h-FFh



## 3. INTRODUCTION

### 3.1 System Architecture

This section describes PC Card basics, windowing, interrupts, VG-PD67XX power management, socket power management, write FIFO, bus sizing, programmable PC Card timing, and ATA and DMA mode operation.

#### 3.1.1 PC Card Basics

PCMCIA is an abbreviation for Personal Computer Memory Card International Association. PC Card Standard<sup>1</sup> is a standard for using memory and I/O devices as insertable, exchangeable peripherals for PCs (personal computers) and handheld computers. For simpler end-user and vendor implementation of the standard, systems employing PC Card Standard should also be backward-compatible with industry-standard PC addressing.

The memory information for memory-type PC Cards must be mapped into the system memory address space. This is accomplished with a 'windowing' technique that is similar to expanded memory schemes already used in PC systems (for example, LIM 4.0 memory manager).

PC Cards can have *attribute* and *common* memory. Attribute memory is used to indicate to host software the capabilities of the PC Card, and it allows host software to change the configuration of the card. Common memory can be used by host software for any purpose (such as flash file system, system memory, and floppy emulation).

I/O-type PC Cards, such as modems, should also be directly addressable, as if the cards were I/O devices plugged into the ISA bus. For example, it would be highly desirable to have a PC Card modem accessible to standard communications software as if it were at a COM port. For COM1, this would require that the modem be accessed at system I/O address 3F8h–3FFh. The method of mapping a PC Card I/O address into anticipated areas of ISA I/O space is done similarly to memory windowing.

I/O-type PC Cards usually have interrupts that need to be serviced by host software. For the example of a modem card accessed as if at COM1, software would expect the modem to generate interrupts on the IRQ4 line. To be sure all interrupts are routed as expected, the VG-PD67XX can steer the interrupt from the PC Card to one of several standard PC interrupts (see Section 3.1.4 and the **Interrupt and General Control** register on page 34).

#### 3.1.2 VG-PD67XX Windowing Capabilities

For full compatibility with existing software, and to ensure compatibility with future memory cards and software, the VG-PD67XX provides five programmable memory windows per socket and two programmable I/O windows per socket. These windows can be used by an inserted PC Card to access ISA memory and I/O space.

Having five memory windows per socket allows a memory-type card to be accessed through four memory windows programmed for common memory access (allowing PC-type expanded-memory-style management), leaving the fifth memory window available to be programmed to access the card's attribute memory without disrupting the common memory in use.

---

<sup>1</sup> The VG-PD67XX is backward-compatible with PCMCIA standards 1.0, 2.0, 2.01, and 2.1. The VG-PD67XX is also compatible with JEIDA 4.1 and its earlier standards corresponding with the PCMCIA standards above.





Each of the five memory windows has several programming options, including:

<b>Memory Window Option</b>	<b>Description</b>
<b>Enabled</b>	Each of the five memory windows can be individually enabled. Disabled windows are not responded to.
<b>Start Address</b>	The starting address of the window is programmable on 4-Kbyte boundaries starting at 64 Kbytes (1000h) with a maximum address of 16 Mbyte.
<b>End Address</b>	The ending address of the window is programmable on 4-Kbyte boundaries starting at 64 Kbytes (1000h) with a maximum address of 16 Mbyte. Only memory accesses between the starting and ending address are responded to.
<b>Offset Address</b>	The offset address is added to the ISA address to determine the address for accessing the PC Card. This allows the addresses in the PC Card address space to be different from the ISA address space.
<b>Data Size</b>	The size of accesses can be set manually to either 8 or 16 bits.
<b>Timing</b>	The timing of accesses (Setup/Command/Recovery) can be set by either of two timing register sets: Timer Set 0 or Timer Set 1.
<b>Register Access Setting</b>	The -REG pin can be enabled on a per-window basis so that any of the windows can be used for accessing attribute memory.
<b>Write Protect</b>	If the window is programmed to be write-protected, then writes to the memory window are ignored (reads are still performed normally).

Each of the two I/O windows has several programming options, including:

<b>I/O Window Option</b>	<b>Description</b>
<b>Enabled</b>	Each of the two I/O windows can be individually enabled.
<b>Start Address</b>	The starting address of the window is programmable on single-byte boundaries from 0 to 64 Kbytes.
<b>End Address</b>	The ending address of the window is also programmable on single-byte boundaries from 0 to 64 Kbytes.
<b>Offset Address</b>	The offset address is added to the ISA address to determine the address for accessing the PC Card.
<b>Auto Size</b>	The size of accesses can be set automatically, based on the PC Card -IOIS16 signal.
<b>Data Size</b>	The size of accesses can be set manually to either 8 or 16 bits, overriding the Auto Size option.
<b>Timing</b>	The timing of accesses (Setup/Command/Recovery) can be set by either of two timing register sets: Timer Set 0 or Timer Set 1.

**CAUTION:** The windows of the VG-PD67XX should never be allowed to overlap with each other or the other devices in the system. This would cause collisions in the IOCS16\*, MEMCS16\*, IOCHRDY, and SD[15:0] signals, resulting in erratic behavior.

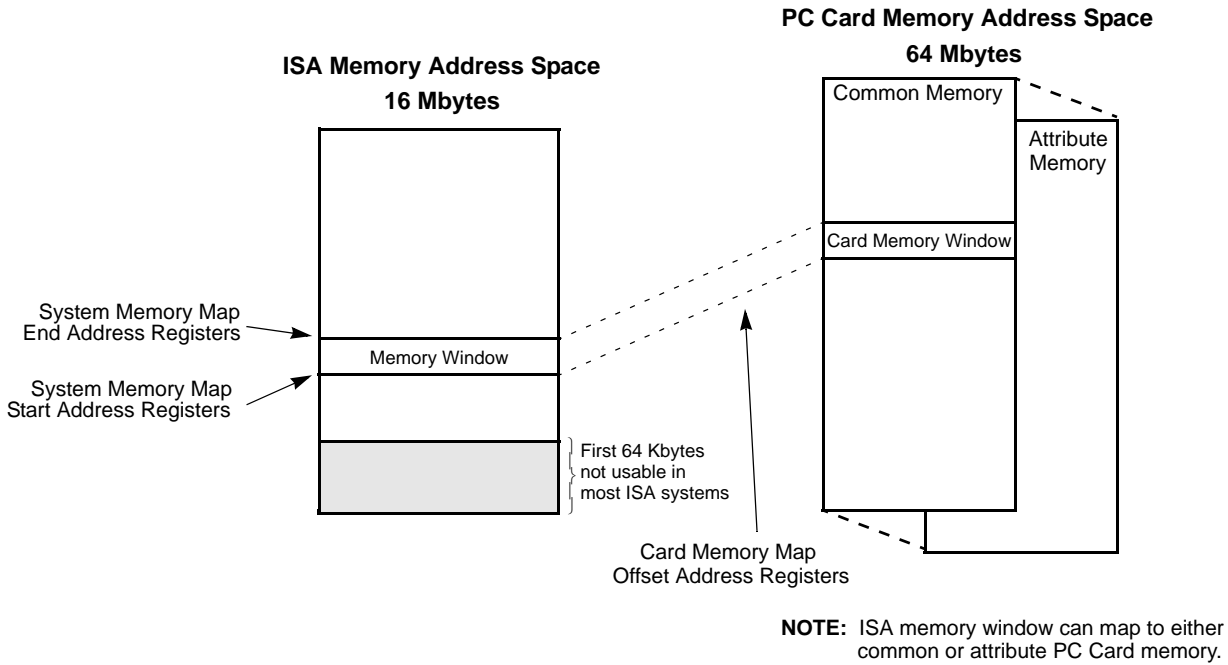

Figure 3-1. Memory Window Organization

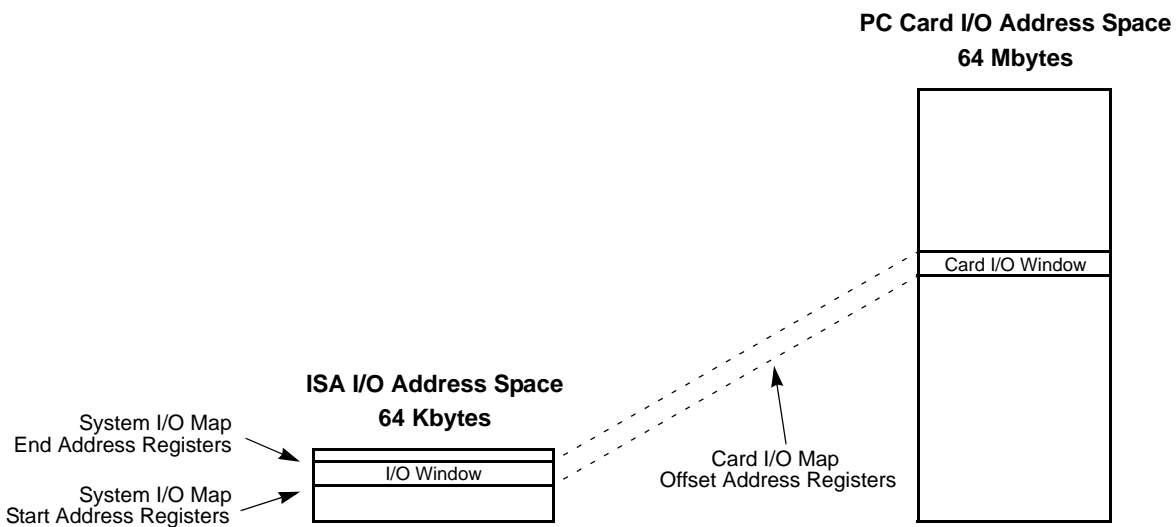
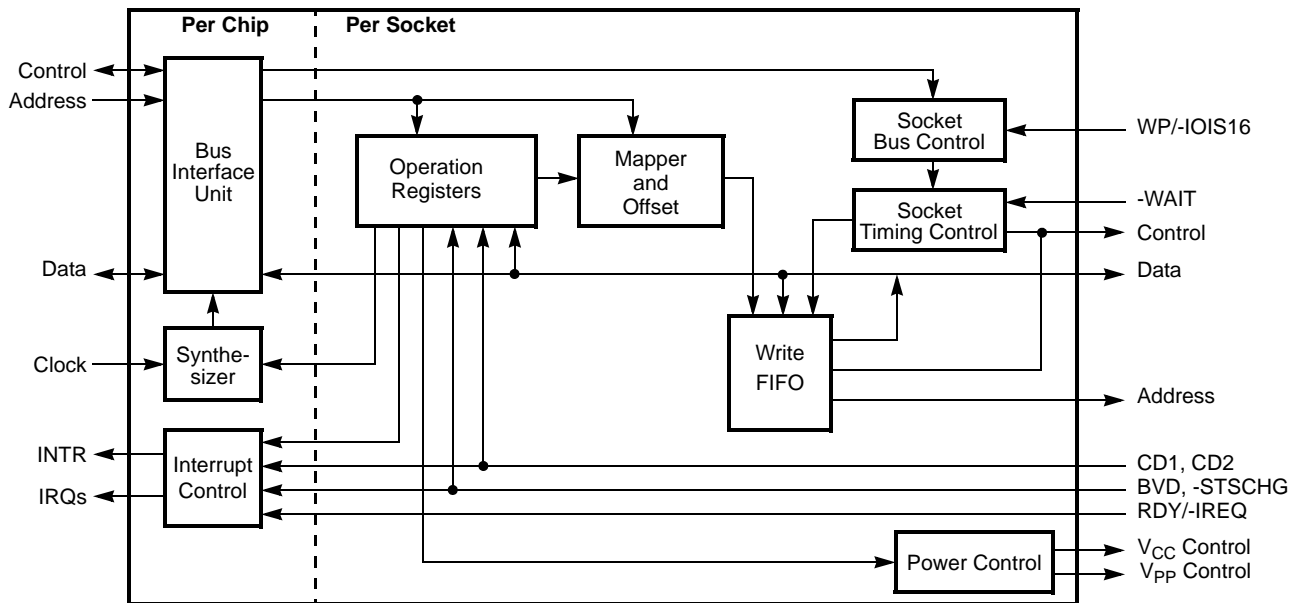

Figure 3-2. I/O Window Organization

### 3.1.3 VG-PD67XX Functional Blocks



**Figure 3-3. Functional Block Diagram**

### 3.1.4 Interrupts

The VG-PD67XX provides ten interrupt pins that are labeled with names suggesting their mapping in the system, though there are no hard requirements specifying the exact mapping. Typically, all ten interrupt pins should be connected to system interrupt signals to allow maximum flexibility in programming interrupt routing from the VG-PD67XX.

#### Classes of Interrupts

The VG-PD67XX supports two classes of interrupts:

- 1 Socket or card interrupts initiated by the PC Card activating its RDY/-IREQ signal
- 1 Management interrupts triggered by changes in PC Card status, including:
  - Card insertion or removal
  - Battery warning indicator (BVD2) change on a memory-type card
  - Battery dead indicator (BVD1) or I/O-type card status change (-STSCHG)
  - Ready (RDY) status change on a memory-type card

Either class of interrupts can be routed to any of the ten interrupt pins on the VG-PD67XX.

#### Connection of Interrupt Pins

IRQ interrupts in PC-compatible systems are not generally shared by hardware. Therefore, each device in the system using IRQ interrupts must have a unique interrupt line. Additionally, many software applications assume that certain I/O devices use specific IRQ signals. To allow PC Cards with differing I/O functionalities to be connected to appropriate nonconflicting IRQ locations, the VG-PD67XX can steer the interrupt signal from a PC Card to any one of the ten different hardware interrupt lines.

For some I/O-type cards, software is written so that IRQ interrupts can be shared. The VG-PD67XX contains unique logic that allows IRQ interrupts to be shared under software control. This is accomplished by programming the VG-PD67XX to alternately pulse and then three-state the desired interrupt pin, which has been programmed as an IRQ output. This unique IRQ interrupt sharing technique can be controlled through software so that systems incapable of IRQ sharing have no loss of functionality.



### 3.1.5 Alternate Functions of Interrupt Pins

The VG-PD67XX has two interrupt pins that can be programmed for alternate functions: IRQ12/LED\_OUT\* and IRQ15/RI\_OUT\*. In addition, the VG-PD6722 allows IRQ9 and IRQ10 to be programmed for system DMA transfer handshake functions.

#### 3.1.5.1 IRQ12 as LED\_OUT\* Driver

If a disk-activity or card-cycle-activity indicator is desired, IRQ12/LED\_OUT\* can be programmed as an open-collector LED driver, capable of driving most common LEDs. There is no specific bit that programs the IRQ12 pin to become an LED driver; instead, whenever a socket interface is programmed to support a drive status LED input or is programmed to show card activity on the LED (as described below), the IRQ12 pin becomes reconfigured as an open-collector LED driver.

The **Extension Control 1** register's LED Activity Enable bit (extended index 03h bit 2) is used to enable the LED being used to show card activity. When this bit is set, any type of read or write cycles to the respective socket cause the IRQ12/LED\_OUT\* signal to be driven low for the duration of the card activity.

The Drive LED Enable bit (**Misc Control 2** register bit 4) is used to enable the BVD2/-SPKR/-LED input from an I/O-interfaced card to be interpreted as a drive LED input, where an open-collector signal driven low on this input will cause the IRQ12/LED\_OUT\* open-collector output to go low.

Any combination of settings of LED Activity Enable and Drive LED Enable bits can be used on each socket, with each type of activity being able to separately cause the LED to be illuminated. Status from non-present or non-activated cards is automatically masked off from causing the IRQ12/LED\_OUT\* signal to be driven low.

#### 3.1.5.2 IRQ15 as RI\_OUT\*

If the capability to 'wake up' a system on an incoming phone call to a PC Card modem is desired, it may be necessary in some systems to use a dedicated wakeup signal to the system's SMI or NMI controller to facilitate this instead of using the normal interrupt connections. If this is the case, the

IRQ15 connection can be reprogrammed to pass through a qualified version of an I/O interfaced card's -RI signal.

IRQ15/RI\_OUT\* is programmed as RI\_OUT\* by programming the IRQ15 Is RI Out bit (**Misc Control 2** register 1Eh bit 7) to '1'. Then if a particular socket supporting a modem is to have its BVD1/-STSCHG/-RI pin passed to the IRQ15/RI\_OUT\* pin, that socket's Ring Indicate Enable bit (**Interrupt and General Control** register 03h bit 7) should be set to '1'.

When the VG-PD67XX is configured this way, a low level at the BVD1/-STSCHG/-RI pin on an I/O interfaced PC Card will cause the IRQ15/RI\_OUT\* signal to become active-low (because it is intended to be connected to an SMI\* or NMI\* input on the system processor or core logic). To prevent multiple SMI or NMI interrupts from occurring on one ring condition, the IRQ15/RI\_OUT\* pin remains low until ISA bus activity resumes, indicated by the resumption of ISA bus memory or I/O reads or writes.

#### 3.1.5.3 IRQ9 as DACK\* and IRQ10 as DRQ

When a VG-PD6722 is to be used for DMA support, IRQ9 is programmed as a DACK\* input from an ISA bus DACK\* signal selected by the system designer. Similarly, IRQ10 is programmed as an active-high DRQ output to the ISA bus and should be connected to the system bus DRQ signal corresponding to that used for DACK\*.

IRQ9 and IRQ10 are thus redefined for DMA cycle support by the setting of the DMA System bit (**Misc Control 2** register 1Eh, bit 6) to '1'. Setting the DMA System bit redefines these ISA interface signals but does not cause DMA to a card to be enabled.

#### 3.1.6 General-Purpose Strobe Feature

The VG-PD6722 has capability to use two pins as general-purpose strobes. This is a feature that causes a pin programmed as a general-purpose strobe to appear in software as an extended register in the VG-PD6722 register set, while in reality accesses to this extended register cause the general-purpose strobe pin to go active during the register access. The strobe can be programmed to



activate on reads or writes to this virtual extended register, allowing straightforward single-chip implementation of an 8-bit general purpose read or write port.

Chapter 11 provides detailed information on how this port can be used.

### **3.1.7 Voltage Sense Pins**

The CL-PD6710 provides a single pin to detect 5 V or 3.3 V on pin 57 of the PC Card.

The VG-PD6722 can be simply configured for dual-socket VS1 and VS2 detection with an external read port consisting of half of a '244 buffer or other similar device, enabled by the B\_GPSTB pin programmed as a read port.

Chapter 12 provides detailed information on the programming model for VS1 and VS2 detection and how connections are made to achieve this functionality.

### **3.1.8 VG-PD67XX Power Management**

To provide the longest possible battery life, the VG-PD67XX provides many power management features, including Low-Power Dynamic mode, Suspend mode, and control of PC Card socket power.

Low-Power Dynamic mode is transparent to the ISA bus. After reset, the VG-PD67XX is configured for Low-Power Dynamic mode. This mode can be turned off by setting **Misc Control 2** register, bit 1 to '0'. When in Low-Power Dynamic mode, periods of inactivity (no activity on the PC Card bus and system accesses to chip registers or inserted cards are no longer being performed) cause the VG-PD67XX to enter a low-power state where the clock is turned off to most of the chip and the PC Card address and data lines are set to a static value.  $V_{CC}$  and  $V_{PP}$  power to the card is left unchanged. When there is activity present on the PC Card bus, or the system accesses VG-PD67XX registers, or PC Cards are inserted or removed from the socket, the VG-PD67XX enters its active state, services the transaction, and then returns to its low-power state.

A Suspend mode can also be programmed. The VG-PD67XX Suspend mode is the chip's lowest software-controlled power mode. The VG-PD67XX is put into Suspend mode by setting the **Misc Con-**

**trol 2** register, bit 2 to '1'. In Suspend mode, all the internal clocks are turned off, and only read/write access to the **Index** register and write access to the **Misc Control 2** register is supported. All accesses to the PC Cards are ignored when in Suspend mode.  $V_{CC}$  and  $V_{PP}$  power to the card is left unchanged (the system power management software is responsible for turning off power to the socket and entering Suspend mode). Interrupts and ring indicate signals are passed through to the system bus when in Suspend mode. To exit Suspend mode, the **Misc Control 2** register bit 2 must be reset to '0'. It requires 50 ms for the VG-PD67XX to restart the internal clock synthesizer and become active again.

In addition to the software suspend, if the system hold's the AEN signal of the VG-PD67XX high, a hardware-assisted Super-Suspend mode occurs where ISA inputs to the chip are internally shut off. Internal in the VG-PD67XX, the ISA inputs are ignored and floating conditions on the ISA bus will not cause high current flow in the VG-PD67XX ISA input receivers. Since the ISA bus inputs to the core logic of the VG-PD67XX are also not toggling when AEN is set high, power consumption is further reduced. Interrupts and ring indicate signals are passed through to the system bus when in Super-Suspend mode

The VG-PD67XX power can be further managed by controlling socket power as outlined in Section 3.1.9. Socket power can be turned on and off through software or automatically when cards are inserted or removed. The VG-PD67XX provides six pins per socket for controlling external logic to switch  $V_{CC}$  and  $V_{PP}$  voltages on and off and for sensing a card's operating voltage range. Cards can be turned off when not in use.



Table 3-1. VG-PD67XX Power-Management Modes

Mode Name	PWRGOOD Level	AEN	Misc Control 2 Register		Functionality	Typical Power Consumption (CORE_VDD = 3.3 V, ISA_VCC, SOCKET_VCC, and +5V = 5.0 V)
			Suspend Mode (Bit 2)	Low-Power Dynamic Mode (Bit 1)		
Low-Power Dynamic (Default)	High	Normal	0	1	Full functionality	< 45 mW high activity, 9–14 mW normal system activity
Normal	High	Normal	0	0	Full functionality	< 85 mW high activity, 18 mW normal system activity
Suspend (Software Controlled)	High	Normal	1	–	8-bit access to <b>Misc Control 2</b> register. No other register access. No card in socket(s).	< 2 mW
Super-Suspend (Hardware Controlled)	High	Static High	1	–	No register access. No card in socket(s). System bus signals disabled (clock off).	< 1 mW
Reset	Low <sup>a</sup>	–	–	–	No register access. No card in socket(s). System bus signals disabled.	9–14 mW

<sup>a</sup> IOR\*, IOW\*, MEMR\*, and MEMW\* must be held high when PWRGOOD is low to prevent manufacturing test mode outputs from driving the system data bus.

### 3.1.9 Socket Power Management Features

#### Card Removal

When a card is removed from a socket, the VG-PD67XX by default automatically disables the V<sub>CC</sub> and V<sub>PP</sub> supplies to the socket. If **Extension Control 1** register bit 1 is '0', card power is prevented from being automatically disabled when a card is removed. The VG-PD67XX can also be configured to have management interrupts notify software of card removal.

#### Card Insertion

Power to the socket is off at reset and whenever there is no card in a socket. When a card is detected (card detect input pins, -CD1 and -CD2, to the VG-PD67XX become asserted low), two independent actions can be programmed to occur.

If the VG-PD67XX has been set for automatic power-on (**Power Control** register bits 4 and 5 are both '1'), the VG-PD67XX automatically enables the socket V<sub>CC</sub> supply (and, if so programmed, the V<sub>PP</sub> supply).

If the VG-PD67XX has been programmed to cause management interrupts for card-detection events, assertion of -CD1 and -CD2 to the VG-PD67XX causes a management interrupt to inform system software that a card was inserted. In the case of manual power detection (**Power Control** register bit 5 is '0'), system software can determine the card's operating voltage range and then power-up the socket and initialize the card (or simply initialize the card if programmed for automatic power-on (**Power Control** register bit 5 is '1' and **Extension Control 1** register bit 1 is '1')).



**3.1.10 Write FIFO**

To increase performance when writing to PC Cards, two, independent, four-word-deep write FIFOs are used. Writes to PC Cards will complete without wait states until the FIFO is full. Register states should not be changed until the write FIFO is empty.

**3.1.11 Bus Sizing**

The VG-PD67XX incorporates logic to automatically detect its connection to 8- or 16-bit buses. This is accomplished by sensing SBHE\* input activity. If the SBHE\* pin is always high (that is, tied to ISA\_VCC), the VG-PD67XX operates in 8-bit mode where all transfers occur on the lower data bus, bits 7:0. Any occurrence of the SBHE\* going low triggers the VG-PD67XX to operate thereafter as a 16-bit device. 16-bit operation of the VG-PD67XX is properly triggered when the SBHE\* input is connected to the system's SBHE\* signal. When the VG-PD67XX is operating in 16-bit mode, all ISA bus transactions are 16-bit whenever possible, even if installed PC cards only support 8-bit transfers. In 16-bit mode, the signals SBHE\* and SA0 are used to specify the width of the data transfer and the location of data on the bus (which byte lane has the data) during 8-bit transfers. The possible combinations for SBHE\* and SA0 are shown in Table 3-2 and Table 3-3.

**Table 3-2. 16-Bit Mode Operation**

16-Bit Mode Transfer Types	SBHE*	SA0
Word	0	0
Upper Byte/Odd Address	0	1
Low Byte/Even Address	1	0
Not Valid	1	1

**Table 3-3. 8-Bit Mode Operation**

8-Bit Mode Transfer Types <sup>a</sup>	SA0
Even Address	0
Odd Address	1

<sup>a</sup> The SBHE\* signal is pulled up. If the SBHE\* signal remains high, the VG-PD67XX causes all transfers to occur on D[7:0] only.

Typically, there are three types of data transfers to and from the VG-PD67XX:

- 1 **16-Bit Transfer from 16-Bit Processor** — The CPU puts the address on the bus. Then the VG-PD67XX identifies the address on the bus as either an 8- or 16-bit transfer. If the transfer is identified as 16-bit, the host acknowledges with the appropriate signal, either MEMCS16\* or IOCS16\*. Data is transferred to/from the data bus as a word on both byte lanes.
- 1 **8-Bit Transfer from 16-Bit Processor** — The CPU puts the address on the bus. Then the VG-PD67XX identifies the address on the bus as either an 8- or 16-bit transfer. In this case, the transfer is identified as an 8-bit transfer. The host queries SA0 and SBHE\* to determine the byte lane on which the transfer is to occur. The data is transferred to/from the data bus (see Table 3-2).
- 1 **8-Bit Transfer from 8-Bit Processor** — The CPU puts the address on the bus. The host determines that it will be an 8-bit transfer since the SBHE\* signal has been tied high. The VG-PD67XX queries SA0 to determine if the byte is odd/even. The data is transferred to/from the Data bus (D[7:0]).

**3.1.12 Programmable PC Card Timing**

The Setup, Command, and Recovery time for the PC Card bus is programmable (see Chapter 9). The VG-PD67XX can be programmed to match the timing requirements of any PC Card. There are two sets of timing registers, Timer Set 0 and Timer Set 1, that can be selected on a per-window basis for both I/O and memory windows.

To be compatible with the 82365SL, the two timing sets are programmed at the rising edge of PWRGOOD to include normal-wait and one-wait-state timing.

**3.1.13 ATA Mode Operation**

The VG-PD67XX supports direct connection to AT-attached-interface hard drives. ATA drives use an interface very similar to the IDE interface found on many popular portable computers. In this mode, the address and data conflict with the floppy drive is handled automatically. See Chapter 10 for more information.



### 3.1.14 DMA Mode Operation for the VG-PD6722

A slave mode Direct Memory Access (DMA) feature exists in the VG-PD6722. To use DMA mode, the **Interrupt and General Control** register, bit 5 must be set to '1' to operate the PC Card in I/O Card Interface mode. PC Card interface DMA handshake signal options must also be selected. Refer to the description of the **Extension Control 1** register on page 58 as well as Chapter 13.

### 3.1.15 Selective Data Drive for I/O Windows

The VG-PD67XX can be programmed to drive only some of the ISA bus data pins on reads from I/O windows. This reduces data contention for I/O addresses that include more than one peripheral. In the standard IBM® PC AT, I/O map, floppy disk, and hard disk share address 3F7h. The floppy disk drives ISA-data-bus bit 7 on a read from 3F7h, and the hard disk drives bits 6:0. To allow both floppy disk controllers on the motherboard and hard disks on the PC Card bus (or vice versa) to coexist, the VG-PD67XX

can be programmed through use of its Data Mask registers to disable bit 7 on I/O reads at addresses 3F7h and 377h. This is done by programming up I/O windows to these addresses as part of the task of configuring a socket for ATA drive support (see page 57). Alternately, all bits except bit 7 can also be disabled to allow the opposite case.

## 3.2 Host Access to Registers

The VG-PD67XX registers are accessed through an 8-bit indexing mechanism. An index register scheme allows a large number of internal registers to be accessed by the CPU using only two I/O addresses.

The **Index** register (see Chapter 4) is used to specify which of the internal registers the CPU will access next. The value in the **Index** register is called the Register Index. This number specifies a unique internal register. The **Data** register is used by the CPU to read and write the internal register specified by the **Index** register.

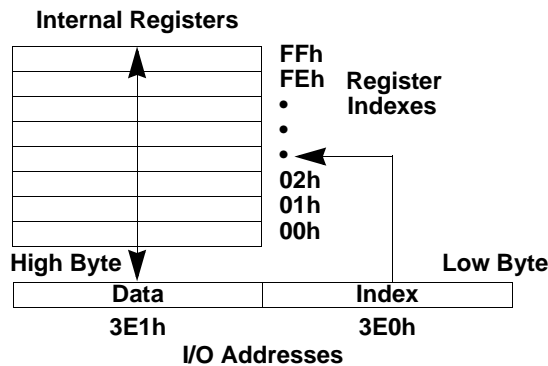
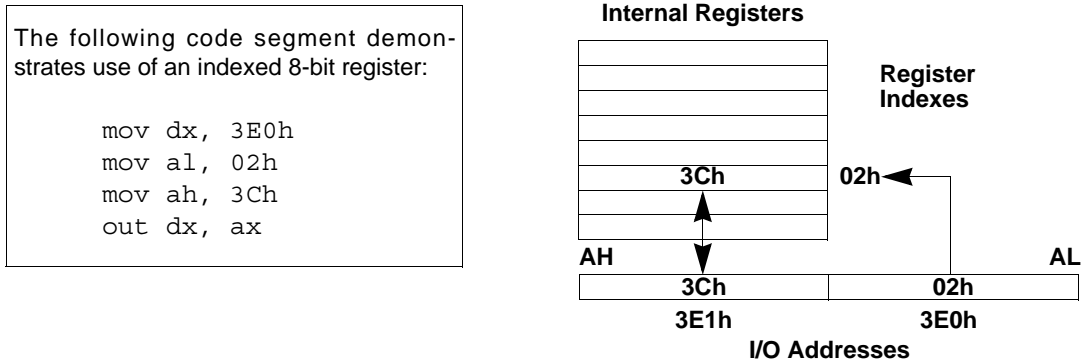

Figure 3-4. Indexed 8-Bit Register Structure





**Figure 3-5. Indexed 8-Bit Register Example**

**Double-Indexed Registers**

The VG-PD67XX has Extension registers that add to the functionality of the 82365SL-compatible register set. Within the Extension registers is an **Extended Index** register and **Extended Data** register that provide access to more registers. The registers accessed through **Extended Index** and **Extended Data** are thus double indexed. The example below shows how to access the **Extension Control 1** register, one of the double-indexed registers.

```

;Write to Extension Control 1 register example

;Constants section
Extended_Index EQU 2Eh
Index_Reg      EQU 2Fh
Ext_Cntrl_1   EQU 03h
PD67XX_Index  EQU 3E0h

;Code section
mov dx, PD67XX_Index
mov al, Extended_Index
mov ah, Ext_Cntrl_1
out dx, ax
mov al, Index_Reg
mov ah, user_data      ;Desired data to be
out dx, ax             ;written to
                       ;extended index 03h

;Read from Extension Control 1 register example

;Code section
mov dx, PD67XX_Index
mov al, Extended_Index
    
```

```

mov ah, Ext_Cntrl_1
out dx, ax
mov al, Index_Reg
out dx, al
inc dx ;al has extended
in al, dx ;index 03h data
    
```

**3.3 Power-On Setup**

Following reset, the VG-PD67XX must be configured by host software. The host software's setup procedure is different depending on its PC system configuration, in particular, the power supply arrangement.

The application of the RESET signal (see page 20) on power-up causes initialization of all the VG-PD67XX register bits and fields to their reset values. Not all registers have reset values; only registers with bits and fields specified to have reset values are initialized.

One bit, which is loaded on hardware reset from the SPKR\_OUT\*/C\_SEL pin (see page 17), is used to determine the socket to which the VG-PD67XX will respond.



### 3. REGISTER DESCRIPTION CONVENTIONS

#### Register Headings

The description of each register starts with a header containing the following information:

Header Field	Description
Register Name	Indicates the register name.
Index <sup>a</sup>	The Index value through which an internal register in an indexed register set is accessed.
Register Per	Indicates whether the register affects both sockets, marked <i>chip</i> , or an individual socket, marked <i>socket</i> . If <i>socket</i> is indicated, there are two registers being described, each with a separate Index value (one for each socket, A and B). <sup>a</sup>
Register Compatibility Type	Indicates whether the register is 82365SL-compatible, marked 365 or a register extension, marked <i>ext</i> .

<sup>a</sup> When the register is socket-specific, the Index value given in the register heading is for Socket A only. For the Socket B register on the VG-PD6722, add 40h to the Index value of the Socket A register.

#### Special Function Bits

Following is a description of bits with special functions:

Bit Type	Description
<i>Reserved</i>	These bits are Reserved and should not be changed.
<i>Compatibility Bit</i>	These bits have no function on the VG-PD67XX, but are included for compatibility with the 82365SL register set.
<i>0 or 1</i>	These read-only bits are forced to either '0' or '1' at reset and cannot be changed.
<i>Scratchpad Bit</i>	These read/write bits are available for use as bits of memory.

#### Bit Naming Conventions

The following keywords are used within bit and field names:

Keyword	Description
Enable	Indicates that the function described in the rest of the bit name is active when the bit is '1'.
Disable	Indicates that the function described in the rest of the bit name is active when the bit is '0'.
Mode	Indicates that the function of the bit alters the interpretation of the values in other registers.
Input	Indicates a bit or field that is read from a pin.
Output	Indicates a bit or field that is driven to a pin.
Select	Indicates that the bit or field selects between multiple alternatives. Fields that contain <i>Select</i> in their names have an indirect mapping between the value of the field and the effect.
Status	Indicates one of two types of bits: either read-only bits used by the VG-PD67XX to report information to the system, or bits set by the VG-PD67XX in response to an event, and can also be cleared by the system. The system cannot directly cause a Status bit to become '1'.
Value	Indicates that the bit or field value is used as a number.

#### Read/Write Convention

Bit Access	Description
RW:n	Bit is read/write and resets to value <i>n</i> when PWRGOOD is cycled.
R	Bit is read-only and setting is determined by conditions noted. Set this bit to '0', or echo back value read.
R:n	Bit is read-only and resets to value <i>n</i> when PWRGOOD is cycled. Set this bit to '0', or echo back value read.
R:n W:m	Bit is read/write and resets to value <i>n</i> when PWRGOOD is cycled. Set this bit to value <i>m</i> only.



## 4. OPERATION REGISTERS

The VG-PD67XX internal registers are accessed through a pair of Operation registers — an **Index** register and a **Data** register. The **Index** register is accessed at address 03E0h, and the **Data** register is accessed at 03E1h.

### 4.1 Index

Register Name: <b>Index</b>				Register Per: chip			
Index: <b>n/a</b>				Register Compatibility Type: 365			
Bit 7	Bit 6	Bit 5	Bit 4	Bit 3	Bit 2	Bit 1	Bit 0
Device Index	Socket Index	Register Index					
RW:0	RW:0	RW:000000					

The **Data** register is accessed at 03E1h.

#### Bits 5:0 — Register Index

These bits determine which of the 64 possible socket-specific registers will be accessed when the **Data** register is next accessed by the processor. Note that some values of the Register Index field are reserved (see Table 4-1).

#### Bit 6 — Socket Index

This bit determines which set of socket-specific registers is currently selected. When this bit is '0', a Socket A register is selected. When this bit is '1', a Socket B register is selected. Note that the CL-PD6710 supports one socket, and the VG-PD6722 supports two sockets.

#### Bit 7 — Device Index

In systems where two VG-PD67XXs are used, this bit differentiates between them.

The **Index** register value determines which internal register should be accessed (read or written) in response to each CPU access of the **Data** register. Each of the possible PC Card sockets is allocated 64 of the 256 locations in the internal register index space.

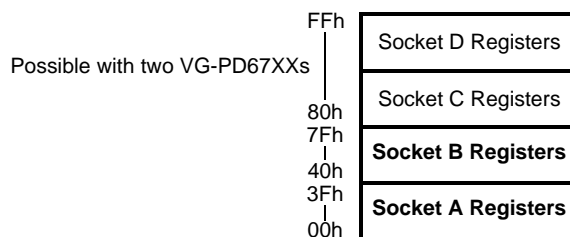

**Figure 4-1. Device/Socket/Register Index Space**

When viewed as a 8-bit value, the contents of the **Index** register completely specify a single internal-register byte. For example, when the value of this register is in the range 00h–3Fh, a Socket A register is selected (Socket Index bit is '0'), and when the value of this register is in the range 40h–7Fh, a Socket B register is selected (Socket Index bit is '1'). This register only reads back for Device 0. Device 1 will read back only the upper data byte when 16-bit reads occur at 3E0h.



The internal register that is accessed when the CPU reads or writes the **Data** register is determined by the current value of the **Index** register, as follows:

**Table 4-1. Index Registers**

Register Name	Index Value		Chapter	Page Number
	Socket A	Socket B <sup>a</sup>		
Chip Revision	00h <sup>b</sup>		Chapter 6: Chip Control	29
Interface Status	01h	41h		30
Power Control	02h	42h		32
Interrupt and General Control	03h	43h		34
Card Status Change	04h	44h		36
Management Interrupt Configuration	05h	45h		37
Mapping Enable	06h	46h		39
I/O Window Control	07h	47h	Chapter 7: I/O Window Mapping	41
System I/O Map 0 Start Address Low	08h	48h		42
System I/O Map 0 Start Address High	09h	49h		42
System I/O Map 0 End Address Low	0Ah	4Ah		43
System I/O Map 0 End Address High	0Bh	4Bh		43
System I/O Map 1 Start Address Low	0Ch	4Ch		42
System I/O Map 1 Start Address High	0Dh	4Dh		42
System I/O Map 1 End Address Low	0Eh	4Eh		43
System I/O Map 1 End Address High	0Fh	4Fh	43	
System Memory Map 0 Start Address Low	10h	50h	Chapter 8: Memory Window Mapping	45
System Memory Map 0 Start Address High	11h	51h		46
System Memory Map 0 End Address Low	12h	52h		46
System Memory Map 0 End Address High	13h	53h		47
Card Memory Map 0 Offset Address Low	14h	54h		48
Card Memory Map 0 Offset Address High	15h	55h		48
Misc Control 1	16h	56h	Chapter 9: Extension	50
FIFO Control	17h	57h		52
System Memory Map 1 Start Address Low	18h	58h	Chapter 8: Memory Window Mapping	45
System Memory Map 1 Start Address High	19h	59h		46
System Memory Map 1 End Address Low	1Ah	5Ah		46
System Memory Map 1 End Address High	1Bh	5Bh	Chapter 8: Memory Window Mapping	47
Card Memory Map 1 Offset Address Low	1Ch	5Ch		48
Card Memory Map 1 Offset Address High	1Dh	5Dh		48
Misc Control 2	1Eh <sup>b</sup>		Chapter 9: Extension	53
Chip Information	1Fh <sup>b</sup>			55
System Memory Map 2 Start Address Low	20h	60h	Chapter 8: Memory Window Mapping	45
System Memory Map 2 Start Address High	21h	61h		46
System Memory Map 2 End Address Low	22h	62h		46
System Memory Map 2 End Address High	23h	63h		47
Card Memory Map 2 Offset Address Low	24h	64h		48
Card Memory Map 2 Offset Address High	25h	65h		48



**Table 4-1. Index Registers (cont.)**

Register Name	Index Value		Chapter	Page Number
	Socket A	Socket B <sup>a</sup>		
ATA Control	26h	66h	Chapter 9: Extension	56
<i>Scratchpad</i>	27h	67h	–	–
System Memory Map 3 Start Address Low	28h	68h	Chapter 8: Memory Window Mapping	45
System Memory Map 3 Start Address High	29h	69h		46
System Memory Map 3 End Address Low	2Ah	6Ah		46
System Memory Map 3 End Address High	2Bh	6Bh		47
Card Memory Map 3 Offset Address Low	2Ch	6Ch		48
Card Memory Map 3 Offset Address High	2Dh	6Dh		48
Extended Index: <sup>c</sup>	2Eh	6Eh		Chapter 9: Extension
<i>Scratchpad</i>	Extended index 00h Extended index 01h Extended index 02h Extended index 03h Extended index 04h Extended index 05h–09h Extended index 0Ah Extended index 0Bh		–	
Data Mask 0			57	
Data Mask 1			58	
Extension Control 1 (formerly DMA Control)			58	
Maximum DMA Acknowledge Delay			59	
<i>Reserved</i>			–	
External Data			61	
Extension Control 2			63	
Extended Data	2Fh	6Fh	57	
System Memory Map 4 Start Address Low	30h	70h	Chapter 8: Memory Window Mapping	45
System Memory Map 4 Start Address High	31h	71h		46
System Memory Map 4 End Address Low	32h	72h		46
System Memory Map 4 End Address High	33h	73h		47
Card Memory Map 4 Offset Address Low	34h	74h		48
Card Memory Map 4 Offset Address High	35h	75h		48
Card I/O Map 0 Offset Address Low	36h	76h		Chapter 7: I/O Window Mapping
Card I/O Map 0 Offset Address High	37h	77h	44	
Card I/O Map 1 Offset Address Low	38h	78h	44	
Card I/O Map 1 Offset Address High	39h	79h	44	
Setup Timing 0	3Ah	7Ah	Chapter 10: Timing	64
Command Timing 0	3Bh	7Bh		65
Recovery Timing 0	3Ch	7Ch		66
Setup Timing 1	3Dh	7Dh		64
Command Timing 1	3Eh	7Eh		65
Recovery Timing 1	3Fh	7Fh		66

<sup>a</sup> Socket B is available on the dual-socket VG-PD6722.

<sup>b</sup> This register affects both sockets (it is not specific to either socket).

<sup>c</sup> These registers are not available on the CL-PD6710.



## 4.2 Data

<i>Register Name: Data</i>				<i>Register Per: chip</i>			
<i>Index: n/a</i>				<i>Register Compatibility Type: 365</i>			
<i>Bit 7</i>	<i>Bit 6</i>	<i>Bit 5</i>	<i>Bit 4</i>	<i>Bit 3</i>	<i>Bit 2</i>	<i>Bit 1</i>	<i>Bit 0</i>
<i>Data</i>							

The **Data** register is accessed at 03E1h. This register indicates the contents of the register at the Device/Socket/Register Index selected by the **Index** register.



## 5. CHIP CONTROL REGISTERS

### 5.1 Chip Revision

<i>Register Name: Chip Revision</i>				<i>Register Per: chip</i>			
<i>Index: 00h</i>				<i>Register Compatibility Type: 365</i>			
<i>Bit 7</i>	<i>Bit 6</i>	<i>Bit 5</i>	<i>Bit 4</i>	<i>Bit 3</i>	<i>Bit 2</i>	<i>Bit 1</i>	<i>Bit 0</i>
Interface ID			0	0	Revision		
R:10			R:0	R:0	R:0010 <sup>a</sup>		

<sup>a</sup> Value for the current stepping only.

#### Bits 3:0 — Revision

This field indicates compatibility with the 82365SL A-step.

#### Bits 7:6 — Interface ID

00	I/O only.
01	Memory only.
10	Memory and I/O.
11	Reserved.

These bits identify what type of interface this controller supports.



## 5.2 Interface Status

<i>Register Name: Interface Status</i>				<i>Register Per: socket</i>			
<i>Index: 01h</i>				<i>Register Compatibility Type: 365</i>			
<i>Bit 7</i> -VPP_VALID	<i>Bit 6</i>	<i>Bit 5</i> RDY	<i>Bit 4</i> WP	<i>Bit 3</i> -CD2	<i>Bit 2</i> -CD1	<i>Bit 1</i> BVD2	<i>Bit 0</i> BVD1
V <sub>PP</sub> Valid	Card Power On	Ready/Busy*	Write Protect	Card Detect		Battery Voltage Detect	
R <sup>a</sup>	R:0	R <sup>b</sup>	R <sup>c</sup>	R <sup>d</sup>		R <sup>e</sup>	

- <sup>a</sup> Bit 7 is the inversion of the value of the -VPP\_VALID pin (see page 17).
- <sup>b</sup> Bit 5 is the value of the RDY/-IREQ pin (see page 19).
- <sup>c</sup> Bit 4 is the value of the WP/-IOIS16 pin (see page 19).
- <sup>d</sup> Bits 3:2 are the inversion of the values of the -CD1 and -CD2 pins (see page 20).
- <sup>e</sup> Bits 1:0 are the values of the BVD1/-STSCHG and BVD2/-SPKR pins (see page 20).

### Bits 1:0 — Battery Voltage Detect

BVD2 Input Level	BVD1 Input Level	Bit 1	Bit 0	PC Card Interpretation
Low	Low	0	0	Card data lost
Low	High	0	1	Battery low warning
High	Low	1	0	Card data lost
High	High	1	1	Battery/data okay

These bits are used by PC Card support software and firmware to indicate the amount of capacity left in the battery in battery-backed cards in Memory Card Interface mode only. In I/O Card Interface mode, bit 0 indicates the state of the BVD1/-STSCHG pin (see page 21). Bit 1 status should be ignored in I/O Card Interface mode.

### Bits 3:2 — Card Detect

-CD2 Level	-CD1 Level	Bit 3	Bit 2	Card Detect Status
High	High	0	0	Either no card or card is not fully inserted
High	Low	0	1	Card is not fully inserted
Low	High	1	0	Card is not fully inserted
Low	Low	1	1	Card is fully inserted

These bits indicate the state of the -CD1 and -CD2 pins (see page 20).

### Bit 4 — Write Protect

0	Card is not write protected.
1	Card is write protected.

This bit indicates the state of the WP/-IOIS16 pin (see page 19) on the card and has meaning only in Memory Card Interface mode.





**Bit 5 — Ready/Busy\***

0	Card is not ready.
1	Card is ready.

This bit indicates the state of the RDY/-IREQ pin (see page 19) on the card. If the card has been configured for I/O, then this bit will not be valid.

**Bit 6 — Card Power On**

0	Power to the card is not on.
1	Power to the card is on.

This status bit indicates whether power to the card is on. Refer to Table 4-1 on page 26 for details.

**Bit 7 — V<sub>PP</sub> Valid**

0	This status bit indicates a logic high at the -VPP_VALID pin.
1	This status bit indicates a logic low at the -VPP_VALID pin.

This bit indicates the status of the -VPP\_VALID pin (see page 17).



### 5.3 Power Control

<i>Register Name: Power Control</i>				<i>Register Per: socket</i>			
<i>Index: 02h</i>				<i>Register Compatibility Type: 365</i>			
<i>Bit 7</i>	<i>Bit 6</i>	<i>Bit 5</i>	<i>Bit 4</i>	<i>Bit 3</i>	<i>Bit 2</i>	<i>Bit 1</i>	<i>Bit 0</i>
Card Enable	Compatibility Bit	Auto-Power	V <sub>CC</sub> Power	Compatibility Bits		V <sub>PP1</sub> Power	
RW:0	RW:0	RW:0	RW:0	RW:00		RW:00	

**Table 5-1. Enabling of Socket Power Controls**

PWR-GOOD Level	Power Control Register		-CD1 and -CD2 Both Active Low	Interface Status Register (see page 30)	-VCC_3 and -VCC_5 Levels	VPP1_PGM and VPP1_VCC Levels
	Bit 4: V <sub>CC</sub> Power	Bit 5: Auto-Power		Bit 6: Card Power On		
Low	X	X	X	0	Inactive high	Inactive low
High	0	X	X	0	Inactive high	Inactive low
High	1	0	X	1	Activated per Misc Control 1 register, bit 1	Activated per Power Control register, bits 1 and 0
High	1	1	No	0	Inactive high	Inactive low
High	1	1	Yes	1	Activated per Misc Control 1 register, bit 1	Activated per Power Control register, bits 1 and 0

**Table 5-2. Enabling of Outputs to Card Socket**

PWR-GOOD Level	-CD1 and -CD2 Both Active Low	Power Control Register		VG-PD67XX Signal Outputs to Socket
		Bit 4: V <sub>CC</sub> Power	Bit 7: Card Enable	
Low	X	X	X	High impedance
High	No	X	X	High impedance
High	Yes	0	0	High impedance
High	Yes	0	1	Enabled
High	Yes	1	0	High impedance
High	Yes	1	1	Enabled



Bit Name	Value	Description
V <sub>CC</sub> Power	1	Enables V <sub>CC</sub> to level described by V <sub>CC</sub> 3.3V (see page 50)
Auto-Power	1	Enables Auto-power mode
Card Enable	1	Enables socket output drivers

### Bits 1:0 — V<sub>PP1</sub> Power

V <sub>PP1</sub> Power Bit 1	V <sub>PP1</sub> Power Bit 0	VPP_PGM	VPP_VCC	PC Card Intended Socket Function
0	0	Inactive low	Inactive low	Zero volts to PC Card socket V <sub>PP1</sub> pin
0	1	Inactive low	Active high <sup>a</sup>	Selected card V <sub>CC</sub> to PC Card socket V <sub>PP1</sub> pin
1	0	Active high <sup>a</sup>	Inactive low	+12V to PC Card socket V <sub>PP1</sub> pin
1	1	Inactive low	Inactive low	Zero volts to PC Card socket V <sub>PP1</sub> pin

<sup>a</sup> Under conditions where V<sub>PP1</sub> power is activated. See Table 5.3.

These bits are intended to be used to control the power to the V<sub>PP1</sub> pin of the PC Card.

### Bit 4 — V<sub>CC</sub> Power

0	Power is not applied to the card: the -VCC_3 and -VCC_5 socket power control pins are inactive high.
1	Power is applied to the card: if bit 5 is '0', or bit 5 is '1' and -CD2 and -CD1 are active low, then the selected -VCC_3 or -VCC_5 socket power control pin is active low.

Depending on the value of bit 5 below, setting this bit to '1' will cause power to be applied to the card. The V<sub>CC</sub> 3.3V bit (see page 50) determines whether 3.3V or 5V power is applied.

### Bit 5 — Auto-Power

0	V <sub>CC</sub> and V <sub>PP1</sub> power control signals are activated independent of the socket's -CD2 and -CD1 input levels.
1	V <sub>CC</sub> and V <sub>PP1</sub> power control signals are only activated if the socket's -CD2 and -CD1 inputs are active low.

When this bit is set to '1', the VG-PD67XX causes power to the card to be turned on and off automatically with the insertion and removal of a PC card from the socket.

### Bit 7 — Card Enable

0	Outputs to card socket are not enabled and are floating.
1	Outputs to card socket are enabled if -CD1 and -CD2 are active low and bit 4 is '1'.

When this bit is '1', the outputs to the PC Card are enabled if a card is present and card power is being supplied. The pins affected include: -CE2, -CE1, -IORD, -IOWR, -OE, -REG, RESET, A[25:0], D[15:0], and -WE (see page 19).



## 5.4 Interrupt and General Control

<i>Register Name:</i> <b>Interrupt and General Control</b>				<i>Register Per:</i> socket			
<i>Index:</i> <b>03h</b>				<i>Register Compatibility Type:</i> 365			
<i>Bit 7</i>	<i>Bit 6</i>	<i>Bit 5</i>	<i>Bit 4</i>	<i>Bit 3</i>	<i>Bit 2</i>	<i>Bit 1</i>	<i>Bit 0</i>
Ring Indicate Enable	Card Reset*	Card Is I/O	Enable Manage Int	Card IRQ Select			
RW:0	RW:0	RW:0	RW:0	RW:0000			

### Bits 3:0 — Card IRQ Select

0000	IRQ disabled
0001	Reserved
0010	Reserved
0011	IRQ 3
0100	IRQ 4
0101	IRQ 5
0110	Reserved
0111	IRQ 7
1000	Reserved
1001	IRQ 9 (On the VG-PD6722, this output may alternately be used as an ISA bus DACK* signal)
1010	IRQ 10 (On the VG-PD6722, this output may alternately be used as an ISA bus DRQ signal)
1011	IRQ 11
1100	IRQ 12 (This output may alternately be used for LED)
1101	Reserved
1110	IRQ 14
1111	IRQ 15 (This output may alternately be used for ring indicate)

These bits determine which IRQ will occur when the card causes an interrupt through the RDY/-IREQ pin on the PC Card connector.

### Bit 4 — Enable Manage Int

0	Card status management interrupts occur as programmed by Management IRQ Select bits (bits 7:4 of <b>Management Interrupt Configuration</b> register, see page 38).
1	Card status management interrupts are redirected to the -INTR line instead of the programmed IRQ pin.

This bit determines how management interrupts will occur.

### Bit 5 — Card Is I/O

0	Memory Card Interface mode: card socket configured to support memory cards. Dual-function socket interface pins perform memory card-type interface functions.
1	I/O Card Interface mode: card socket configured to support I/O/memory card-type interface functions. Dual-function socket interface pins perform I/O/memory card-type interface functions.

This bit determines how dual-function socket interface pins will be used.



**Bit 6 — Card Reset\***

0	The RESET signal to the card socket is set active (high for normal, low for ATA mode).
1	The RESET signal to the card socket is set inactive (low for normal, high for ATA mode).

This bit determines whether the RESET signal (see page 20) to the card is active or inactive. When the Card Enable bit (see page 33) is '0', the RESET signal to the card will be high-impedance. See Chapter 10 for further description of ATA mode functions.

**Bit 7 — Ring Indicate Enable**

0	BVD1/-STSCHG pin is status change function.
1	BVD1/-STSCHG pin is ring indicate input pin from card.

This bit determines whether the -STSCHG input pin is used to activate the IRQ15 pin in conjunction with **Misc Control 2**, IRQ15 Is RI Out (see page 54). This bit has no significance when the card socket is configured for memory card operation.



## 5.5 Card Status Change

Register Name: <b>Card Status Change</b>				Register Per: socket			
Index: <b>04h</b>				Register Compatibility Type: 365			
Bit 7	Bit 6	Bit 5	Bit 4	Bit 3	Bit 2	Bit 1	Bit 0
0	0	0	0	Card Detect Change	Ready Change	Battery Warning Change	Battery Dead Or Status Change
R:0	R:0	R:0	R:0	R:0	R:0	R:0	R:0

This register indicates the source of a management interrupt generated by the VG-PD67XX.

**NOTE:** The corresponding bit in the **Management Interrupt Configuration** register must be set to '1' to enable each specific status change detection.

### Bit 0 — Battery Dead Or Status Change

0	A transition (from high to low for memory card support or either high to low or low to high for I/O card support) on the BVD1/-STSCHG pin has not occurred since this register was last read.
1	A transition on the BVD1/-STSCHG pin has occurred.

When the socket is configured for memory card support, this bit is set to '1' when a BVD1 battery dead high-to-low transition has been detected. When the socket is configured for I/O card support, this bit is set to '1' when the BVD1/-STSCHG pin (see page 21) changes from either high to low or low to high. This bit is reset to '0' whenever this register is read. In I/O Card Interface mode, function of this bit is not affected by bit 7 of the **Interrupt and General Control** register.

### Bit 1 — Battery Warning Change

0	A transition (from high to low) on the BVD2 pin has not occurred since this register was last read.
1	A transition on the BVD2 pin has occurred.

When a socket is configured for memory card support, this bit is set to '1' when a high-to-low transition on BVD2 occurs indicating a battery warning was detected. This bit should be ignored when the socket is configured for I/O card support. This bit is reset to '0' whenever this register is read.

### Bit 2 — Ready Change

0	A transition on the RDY/-IREQ pin has not occurred since this register was last read.
1	A transition on the RDY/-IREQ pin has occurred.

When this bit is '1', a change has occurred in the card RDY/-IREQ pin (see page 19). This bit will always read 0 when the card is configured as an I/O card. This bit is reset to '0' whenever this register is read.

### Bit 3 — Card Detect Change

0	A transition on the -CD1 or -CD2 pins has not occurred since this register was last read.
1	A transition on the -CD1 or -CD2 pins has occurred.

When this bit is '1', a change has occurred on the -CD1 or -CD2 pins (see page 20). This bit is reset to '0' whenever this register is read.



## 5.6 Management Interrupt Configuration

<i>Register Name:</i> <b>Management Interrupt Configuration</b>				<i>Register Per:</i> socket			
<i>Index:</i> <b>05h</b>				<i>Register Compatibility Type:</i> 365			
<i>Bit 7</i>	<i>Bit 6</i>	<i>Bit 5</i>	<i>Bit 4</i>	<i>Bit 3</i>	<i>Bit 2</i>	<i>Bit 1</i>	<i>Bit 0</i>
Management IRQ Select				Card Detect Enable	Ready Enable	Battery Warning Enable	Battery Dead Or Status Change Enable
RW:0000				RW:0	RW:0	RW:0	RW:0

This register controls which status changes may cause management interrupts and at which pin the management interrupts will appear.

### Bit 0 — Battery Dead Or Status Change Enable

0	Battery Dead Or Status Change management interrupt disabled.
1	If Battery Dead Or Status Change is '1', a management interrupt will occur.

When this bit is '1', a management interrupt will occur when the **Card Status Change** register's Battery Dead Or Status Change bit (see page 36) is '1'. This allows management interrupts to be generated on changes in level of the BVD1/-STSCHG pin.

### Bit 1 — Battery Warning Enable

0	Battery Warning Change management interrupt disabled.
1	If Battery Warning Change is '1', a management interrupt will occur.

When this bit is '1', a management interrupt will occur when the **Card Status Change** register's Battery Warning Change bit (see page 36) is '1'. This bit is ignored when the card socket is in I/O mode.

### Bit 2 — Ready Enable

0	Ready Change management interrupt disabled.
1	If Ready Change is '1', a management interrupt will occur.

When this bit is '1', a management interrupt will occur when the **Card Status Change** register's Ready Change bit (see page 36) is '1'.

### Bit 3 — Card Detect Enable

0	Card Detect Change management interrupt disabled.
1	If Card Detect Change is '1', a management interrupt will occur.

When this bit is '1', a management interrupt will occur when the **Card Status Change** register's Card Detect Change bit (see page 36) is '1'.



**Bits 7:4 — Management IRQ Select**

0000	IRQ disabled
0001	Reserved
0010	Reserved
0011	IRQ 3
0100	IRQ 4
0101	IRQ 5
0110	Reserved
0111	IRQ 7
1000	Reserved
1001	IRQ 9 (On the VG-PD6722, this output may alternately be used as an ISA bus DACK* signal)
1010	IRQ 10 (On the VG-PD6722, this output may alternately be used as an ISA bus DRQ signal)
1011	IRQ 11
1100	IRQ 12 (This output may alternately be used for LED)
1101	Reserved
1110	IRQ 14
1111	IRQ 15 (This output may alternately be used for ring indicate)

These bits determine which interrupt pin will be used for card status change management interrupts.





## 5.7 Mapping Enable

<i>Register Name: Mapping Enable</i>						<i>Register Per: socket</i>	
<i>Index: 06h</i>						<i>Register Compatibility Type: 365</i>	
<i>Bit 7</i>	<i>Bit 6</i>	<i>Bit 5</i>	<i>Bit 4</i>	<i>Bit 3</i>	<i>Bit 2</i>	<i>Bit 1</i>	<i>Bit 0</i>
I/O Map 1 Enable	I/O Map 0 Enable	MEMCS16 Full Decode	Memory Map 4 Enable	Memory Map 3 Enable	Memory Map 2 Enable	Memory Map 1 Enable	Memory Map 0 Enable
RW:0	RW:0	RW:0	RW:0	RW:0	RW:0	RW:0	RW:0

### Bit 0 — Memory Map 0 Enable

0	Memory Mapping registers for Memory Space 0 disabled.
1	Memory Mapping registers for Memory Space 0 enabled.

When this bit is '1', the Memory Mapping registers for Memory Space 0 will be enabled and the controller will respond to memory accesses in the memory space defined by those registers.

### Bit 1 — Memory Map 1 Enable

0	Memory Mapping registers for Memory Space 1 disabled.
1	Memory Mapping registers for Memory Space 1 enabled.

When this bit is '1', the Memory Mapping registers for Memory Space 1 will be enabled and the controller will respond to memory accesses in the memory space defined by those registers.

### Bit 2 — Memory Map 2 Enable

0	Memory Mapping registers for Memory Space 2 disabled.
1	Memory Mapping registers for Memory Space 2 enabled.

When this bit is '1', the Memory Mapping registers for Memory Space 2 will be enabled and the controller will respond to memory accesses in the memory space defined by those registers.

### Bit 3 — Memory Map 3 Enable

0	Memory Mapping registers for Memory Space 3 disabled.
1	Memory Mapping registers for Memory Space 3 enabled.

When this bit is '1', the Memory Mapping registers for Memory Space 3 will be enabled and the controller will respond to memory accesses in the memory space defined by those registers.

### Bit 4 — Memory Map 4 Enable

0	Memory Mapping registers for Memory Space 4 disabled.
1	Memory Mapping registers for Memory Space 4 enabled.

When this bit is '1', the Memory Mapping registers for Memory Space 4 will be enabled and the controller will respond to memory accesses in the memory space defined by those registers.

### Bit 5 — MEMCS16 Full Decode

This bit is not used. All addresses are used to determine the level of MEMCS16\*.



**Bit 6 — I/O Map 0 Enable**

0	I/O Mapping registers for I/O Space 0 disabled.
1	I/O Mapping registers for I/O Space 0 enabled.

When this bit is '1', the I/O Mapping registers for I/O Space 0 will be enabled and the controller will respond to I/O accesses in the I/O space defined by those registers.

**Bit 7 — I/O Map 1 Enable**

0	I/O Mapping registers for I/O Space 1 disabled.
1	I/O Mapping registers for I/O Space 1 enabled.

When this bit is '1', the I/O Mapping registers for I/O Space 1 will be enabled and the controller will respond to I/O accesses in the I/O space defined by those registers.



## 6. I/O WINDOW MAPPING REGISTERS

The I/O windows must never include 3E0h and 3E1h.

### 6.1 I/O Window Control

Register Name: I/O Window Control					Register Per: socket		
Index: 07h					Register Compatibility Type: 365		
Bit 7	Bit 6	Bit 5	Bit 4	Bit 3	Bit 2	Bit 1	Bit 0
Timing Register Select 1	Compatibility Bit	Auto-Size I/O Window 1	I/O Window 1 Size	Timing Register Select 0	Compatibility Bit	Auto-Size I/O Window 0	I/O Window 0 Size
RW:0	RW:0	RW:0	RW:0	RW:0	RW:0	RW:0	RW:0

#### Bit 0 — I/O Window 0 Size

0	8-bit data path to I/O Window 0.
1	16-bit data path to I/O Window 0.

When bit 1 below is '0', this bit determines the size of the data path to I/O Window 0. When bit 1 is '1', this bit is ignored.

#### Bit 1 — Auto-Size I/O Window 0

0	I/O Window 0 Size (see bit 0 above) determines the data path to I/O Window 0.
1	The data path to I/O Window 0 will be determined based on -IOIS16 returned by the card.

This bit determines the data path to I/O Window 0. Note that when this bit is '1', the -IOIS16 signal (see page 19) determines the width of the data path to the card.

#### Bit 3 — Timing Register Select 0

0	Accesses made with timing specified in Timing Set 0.
1	Accesses made with timing specified in Timing Set 1.

This bit determines the access timing specification for I/O Window 0 (see page 64).

#### Bit 4 — I/O Window 1 Size

0	8-bit data path to I/O Window 1.
1	16-bit data path to I/O Window 1.

When bit 5 below is '0', this bit determines the size of the data path to I/O Window 1. When bit 5 is '1', this bit is ignored.

#### Bit 5 — Auto-Size I/O Window 1

0	I/O Window 1 Size (see bit 4) determines the data path to I/O Window 1.
1	The data path to I/O Window 1 will be determined based on -IOIS16 returned by the card.

This bit determines the width of the data path to I/O Window 1. Note that when this bit is '1', the -IOIS16 signal (see page 19) determines the window size. This bit must be set for proper ATA mode operation (see Chapter 10).



**Bit 7 — Timing Register Select 1**

0	Accesses made with timing specified in Timing Set 0.
1	Accesses made with timing specified in Timing Set 1.

This bit determines the access timing specification for I/O Window 1 (see page 64).

**6.2 System I/O Map 0–1 Start Address Low**

<i>Register Name:</i> <b>System I/O Map 0–1 Start Address Low</b>						<i>Register Per:</i> socket	
<i>Index:</i> <b>08h, 0Ch</b>						<i>Register Compatibility Type:</i> 365	
Bit 7	Bit 6	Bit 5	Bit 4	Bit 3	Bit 2	Bit 1	Bit 0
Start Address 7:0							
RW:00000000							

There are two separate System I/O Map Start Address Low registers, each with identical fields. These registers are located at the following indexes:

Index	System I/O Map Start Address Low
8h	System I/O Map 0 Start Address Low
Ch	System I/O Map 1 Start Address Low

**Bits 7:0 — Start Address 7:0**

This register contains the least-significant byte of the address that specifies the beginning of the I/O space within the corresponding I/O map. I/O accesses that are equal or above this address and equal or below the corresponding System I/O Map End Address will be mapped into the I/O space of the corresponding PC Card.

The most-significant byte is located in the **System I/O Map 0–1 Start Address High** register (see page 42).

**6.3 System I/O Map 0–1 Start Address High**

<i>Register Name:</i> <b>System I/O Map 0–1 Start Address High</b>						<i>Register Per:</i> socket	
<i>Index:</i> <b>09h, 0Dh</b>						<i>Register Compatibility Type:</i> 365	
Bit 7	Bit 6	Bit 5	Bit 4	Bit 3	Bit 2	Bit 1	Bit 0
Start Address 15:8							
RW:00000000							

There are two separate System I/O Map Start Address High registers, each with identical fields. These registers are located at the following indexes:

Index	System I/O Map Start Address High
9h	System I/O Map 0 Start Address High
Dh	System I/O Map 1 Start Address High

**Bits 15:8 — Start Address 15:8**

This register contains the most-significant byte of the Start Address. See the description of the Start Address field associated with bits 7:0 of the **System I/O Map 0–1 Start Address Low** register.



## 6.4 System I/O Map 0–1 End Address Low

Register Name: <b>System I/O Map 0–1 End Address Low</b>						Register Per: socket	
Index: <b>0Ah, 0Eh</b>						Register Compatibility Type: 365	
Bit 7	Bit 6	Bit 5	Bit 4	Bit 3	Bit 2	Bit 1	Bit 0
End Address 7:0							
RW:00000000							

There are two separate System I/O Map End Address Low registers, each with identical fields. These registers are located at the following indexes:

Index	System I/O Map End Address Low
Ah	System I/O Map 0 End Address Low
Eh	System I/O Map 1 End Address Low

### Bits 7:0 — End Address 7:0

This register contains the least-significant byte of the address that specifies the termination of the I/O space within the corresponding I/O map. I/O accesses that are equal or below this address and equal or above the corresponding System I/O Map Start Address will be mapped into the I/O space of the corresponding PC Card.

The most-significant byte is located in the **System I/O Map 0–1 End Address High** register (see page 43).

## 6.5 System I/O Map 0–1 End Address High

Register Name: <b>System I/O Map 0–1 End Address High</b>						Register Per: socket	
Index: <b>0Bh, 0Fh</b>						Register Compatibility Type: 365	
Bit 7	Bit 6	Bit 5	Bit 4	Bit 3	Bit 2	Bit 1	Bit 0
End Address 15:8							
RW:00000000							

There are two separate System I/O Map End Address High registers, each with identical fields. These registers are located at the following indexes:

Index	System I/O Map End Address High
Bh	System I/O Map 0 End Address High
Fh	System I/O Map 1 End Address High

### Bits 15:8 — End Address 15:8

This register contains the most-significant byte of the End Address. See the description of the End Address field associated with bits 7:0 of the **System I/O Map 0–1 End Address Low** register (see page 43).



## 6.6 Card I/O Map 0–1 Offset Address Low

<i>Register Name:</i> <b>Card I/O Map 0–1 Offset Address Low</b>							<i>Register Per:</i> socket
<i>Index:</i> <b>36h, 38h</b>							<i>Register Compatibility Type:</i> ext.
<i>Bit 7</i>	<i>Bit 6</i>	<i>Bit 5</i>	<i>Bit 4</i>	<i>Bit 3</i>	<i>Bit 2</i>	<i>Bit 1</i>	<i>Bit 0</i>
Offset Address 7:1							0 <sup>a</sup>
RW:0000000							RW:0

<sup>a</sup> This bit must be programmed to '0'.

There are two separate Card I/O Map Offset Address Low registers, each with identical fields. These registers are located at the following indexes:

Index	Card I/O Map Offset Address Low
36h	Card I/O Map 0 Offset Address Low
38h	Card I/O Map 1 Offset Address Low

### Bits 7:1 — Offset Address 7:1

This register contains the least-significant byte of the quantity that will be added to the host I/O address; this will determine the PC Card I/O map location where the I/O access will occur.

The most-significant byte is located in the **Card I/O Map 0–1 Offset Address High** register (see page 44).

## 6.7 Card I/O Map 0–1 Offset Address High

<i>Register Name:</i> <b>Card I/O Map 0–1 Offset Address High</b>							<i>Register Per:</i> socket
<i>Index:</i> <b>37h, 39h</b>							<i>Register Compatibility Type:</i> ext.
<i>Bit 7</i>	<i>Bit 6</i>	<i>Bit 5</i>	<i>Bit 4</i>	<i>Bit 3</i>	<i>Bit 2</i>	<i>Bit 1</i>	<i>Bit 0</i>
Offset Address 15:8							
RW:00000000							

There are two separate Card I/O Map Offset Address High registers, each with identical fields. These registers are located at the following indexes:

Index	Card I/O Map Offset Address High
37h	Card I/O Map 0 Offset Address High
39h	Card I/O Map 1 Offset Address High

### Bits 15:8 — Offset Address 15:8

This register contains the most-significant byte of the Offset Address. See the description of the End Address field associated with bits 7:1 of the **Card I/O Map 0–1 Offset Address Low** register (see page 44).



## 7. MEMORY WINDOW MAPPING REGISTERS

The following information about the memory map windows is important:

- 1 The memory window mapping registers determine where in the ISA memory space and PC Card memory space accesses will occur. There are five memory windows that can be used independently.
- 1 The memory windows are enabled and disabled using the **Mapping Enable** register (see page 39).
- 1 To specify where in the ISA space a memory window is mapped, start and end addresses are specified. A memory window is selected whenever the appropriate Memory Map Enable bit (see page 39) is set, and when the ISA address is greater than or equal to the appropriate **System Memory Map Start Address** register (see page 45) and the ISA address is less than or equal to the appropriate **System Memory Map End Address** register (see page 46).
- 1 Start and end addresses are specified with ISA Address bits 23:12. This sets the minimum size of a memory window to 4K bytes. Memory windows are specified in the ISA address from 64 Kbytes to 16 Mbytes (0010000h–FFFFFFh). Note that no memory window can be mapped in the first 64 Kbytes of the ISA address space.
- 1 To ensure proper operation, none of the windows can overlap in the ISA address space.

### 7.1 System Memory Map 0–4 Start Address Low

<i>Register Name:</i> <b>System Memory Map 0–4 Start Address Low</b>					<i>Register Per:</i> socket		
<i>Index:</i> <b>10h, 18h, 20h, 28h, 30h</b>					<i>Register Compatibility Type:</i> 365		
<i>Bit 7</i>	<i>Bit 6</i>	<i>Bit 5</i>	<i>Bit 4</i>	<i>Bit 3</i>	<i>Bit 2</i>	<i>Bit 1</i>	<i>Bit 0</i>
Start Address 19:12							
RW:00000000							

There are five separate System Memory Map Start Address Low registers, each with identical fields. These registers are located at the following indexes:

Index	System Memory Map Start Address Low
10h	System Memory Map 0 Start Address Low
18h	System Memory Map 1 Start Address Low
20h	System Memory Map 2 Start Address Low
28h	System Memory Map 3 Start Address Low
30h	System Memory Map 4 Start Address Low

#### Bits 7:0 — Start Address 19:12

This register contains the least-significant byte of the address that specifies where in the memory space the corresponding memory map will begin. Memory accesses that are equal or above this address and equal or below the corresponding System Memory Map End Address will be mapped into the memory space of the corresponding PC Card.

The most-significant four bits are located in the **System Memory Map 0–4 Start Address High** register (see page 46).



## 7.2 System Memory Map 0–4 Start Address High

<i>Register Name:</i> <b>System Memory Map 0–4 Start Address High</b>					<i>Register Per:</i> socket		
<i>Index:</i> <b>11h, 19h, 21h, 29h, 31h</b>					<i>Register Compatibility Type:</i> 365		
<i>Bit 7</i>	<i>Bit 6</i>	<i>Bit 5</i>	<i>Bit 4</i>	<i>Bit 3</i>	<i>Bit 2</i>	<i>Bit 1</i>	<i>Bit 0</i>
Window Data Size	Compatibility Bit	Scratchpad Bits			Start Address 23:20		
RW:0	RW:0	RW:00			RW:0000		

There are five separate System Memory Map Start Address High registers, each with identical fields. These registers are located at the following indexes:

<b>Index</b>	<b>System Memory Map Start Address High</b>
11h	System Memory Map 0 Start Address High
19h	System Memory Map 1 Start Address High
21h	System Memory Map 2 Start Address High
29h	System Memory Map 3 Start Address High
31h	System Memory Map 4 Start Address High

### Bits 3:0 — Start Address 23:20

This field contains the most-significant four bits of the Start Address. See the description of the Start Address field associated with bits 7:0 of the **System Memory Map 0–4 Start Address Low** register (see page 45).

### Bit 7 — Window Data Size

0	8-bit data path to the card.
1	16-bit data path to the card.

This bit determines the data path size to the card.

## 7.3 System Memory Map 0–4 End Address Low

<i>Register Name:</i> <b>System Memory Map 0–4 End Address Low</b>					<i>Register Per:</i> socket		
<i>Index:</i> <b>12h, 1Ah, 22h, 2Ah, 32h</b>					<i>Register Compatibility Type:</i> 365		
<i>Bit 7</i>	<i>Bit 6</i>	<i>Bit 5</i>	<i>Bit 4</i>	<i>Bit 3</i>	<i>Bit 2</i>	<i>Bit 1</i>	<i>Bit 0</i>
End Address 19:12							
RW:00000000							

There are five separate System Memory Map End Address Low registers, each with identical fields. These registers are located at the following indexes:

<b>Index</b>	<b>System Memory Map End Address Low</b>
12h	System Memory Map 0 End Address Low
1Ah	System Memory Map 1 End Address Low
22h	System Memory Map 2 End Address Low
2Ah	System Memory Map 3 End Address Low
32h	System Memory Map 4 End Address Low





**Bits 7:0 — End Address 19:12**

This register contains the least-significant byte of the address that specifies where in the memory space the corresponding memory map will end. Memory accesses that are equal or below this address and equal or above the corresponding System Memory Map Start Address will be mapped into the memory space of the corresponding PC Card.

The most-significant four bits are located in the **System Memory Map 0–4 End Address High** register (see Section 7.4).

**7.4 System Memory Map 0–4 End Address High**

<i>Register Name: System Memory Map 0–4 End Address High</i>				<i>Register Per: socket</i>			
<i>Index: 13h, 1Bh, 23h, 2Bh, 33h</i>				<i>Register Compatibility Type: 365</i>			
<i>Bit 7</i>	<i>Bit 6</i>	<i>Bit 5</i>	<i>Bit 4</i>	<i>Bit 3</i>	<i>Bit 2</i>	<i>Bit 1</i>	<i>Bit 0</i>
Card Timer Select		Scratchpad Bits		End Address 23:20			
RW:00		RW:00		RW:0000			

There are five separate System Memory Map End Address High registers, each with identical fields. These registers are located at the following indexes:

<b>Index</b>	<b>System Memory Map End Address High</b>
13h	System Memory Map 0 End Address High
1Bh	System Memory Map 1 End Address High
23h	System Memory Map 2 End Address High
2Bh	System Memory Map 3 End Address High
33h	System Memory Map 4 End Address High

**Bits 3:0 — End Address 23:20**

This field contains the most-significant four bits of the End Address. See the description of the End Address field associated with bits 7:0 of the **System Memory Map 0–4 End Address Low** register (see page 46).

**Bits 7:6 — Card Timer Select**

00	Selects Timer Set 0.
01	Selects Timer Set 1.
10	Selects Timer Set 1.
11	Selects Timer Set 1.

This field selects the Timeset registers used to control socket timing for card accesses in this window address range. Timeset 0 and 1 reset to values compatible with PC Card standards. The mapping of bits 7:6 to Timeset 0 and 1, as shown in the preceding table, is done for software compatibility with older ISA bus-based PCMCIA host adapters that use ISA bus wait states instead of Timeset registers (see page 64).



### 7.5 Card Memory Map 0–4 Offset Address Low

<i>Register Name:</i> <b>Card Memory Map 0–4 Offset Address Low</b>						<i>Register Per:</i> socket	
<i>Index:</i> <b>14h, 1Ch, 24h, 2Ch, 34h</b>						<i>Register Compatibility Type:</i> 365	
<i>Bit 7</i>	<i>Bit 6</i>	<i>Bit 5</i>	<i>Bit 4</i>	<i>Bit 3</i>	<i>Bit 2</i>	<i>Bit 1</i>	<i>Bit 0</i>
Offset Address 19:12							
RW:00000000							

There are five separate Card Memory Map Offset Address Low registers, each with identical fields. These registers are located at the following indexes:

<b>Index</b>	<b>Card Memory Map Offset Address Low</b>
14h	Card Memory Map 0 Offset Address Low
1Ch	Card Memory Map 1 Offset Address Low
24h	Card Memory Map 2 Offset Address Low
2Ch	Card Memory Map 3 Offset Address Low
34h	Card Memory Map 4 Offset Address Low

#### Bits 7:0 — Offset Address 19:12

This register contains the least-significant byte of the quantity that will be added to the host memory address, which will determine where the memory access will occur in the PC Card memory map.

The most-significant six bits are located in the **Card Memory Map 0–4 Offset Address High** register (see page 48).

### 7.6 Card Memory Map 0–4 Offset Address High

<i>Register Name:</i> <b>Card Memory Map 0–4 Offset Address High</b>						<i>Register Per:</i> socket	
<i>Index:</i> <b>15h, 1Dh, 25h, 2Dh, 35h</b>						<i>Register Compatibility Type:</i> 365	
<i>Bit 7</i>	<i>Bit 6</i>	<i>Bit 5</i>	<i>Bit 4</i>	<i>Bit 3</i>	<i>Bit 2</i>	<i>Bit 1</i>	<i>Bit 0</i>
Write Protect	REG Setting	Offset Address 25:20					
RW:0	RW:0	RW:000000					

There are five separate Card Memory Map Offset Address High registers, each with identical fields. These registers are located at the following indexes:

<b>Index</b>	<b>Card Memory Map Offset Address High</b>
15h	Card Memory Map 0 Offset Address High
1Dh	Card Memory Map 1 Offset Address High
25h	Card Memory Map 2 Offset Address High
2Dh	Card Memory Map 3 Offset Address High
35h	Card Memory Map 4 Offset Address High



**Bits 5:0 — Offset Address 25:20**

This field contains the most-significant six bits of the Offset Address. See the description of the Offset Address field associated with bits 7:0 of the **Card Memory Map 0–4 Offset Address Low** register (see page 48).

**Bit 6 — REG Setting**

0	-REG (see page 18) is not active for accesses made through this window.
1	-REG is active for accesses made through this window.

This bit determines whether -REG (see page 18) will be active for accesses made through this window. Card Information Structure (CIS) memory is accessed by setting this bit to '1'.

**Bit 7 — Write Protect**

0	Writes to the card through this window are allowed.
1	Writes to the card through this window are inhibited.

This bit determines whether writes to the card through this window are allowed. This bit only applies to Memory Card Interface mode.

**NOTE:** This bit must be set to '0' and a memory card's 'WP' switch must be turned off to allow writes to a card using a memory interface, such as an SRAM card.



## 8. EXTENSION REGISTERS

### 8.1 Misc Control 1

<i>Register Name:</i> <b>Misc Control 1</b>				<i>Register Per:</i> socket			
<i>Index:</i> <b>16h</b>				<i>Register Compatibility Type:</i> ext.			
<i>Bit 7</i>	<i>Bit 6</i>	<i>Bit 5</i>	<i>Bit 4</i>	<i>Bit 3</i>	<i>Bit 2</i>	<i>Bit 1</i>	<i>Bit 0</i>
Inpack Enable	<i>Scratchpad Bits</i>		Speaker Enable	Pulse System IRQ	Pulse Management Interrupt	V <sub>CC</sub> 3.3V	5 V Detect (CL-PD6710)  Reserved <sup>a</sup> (VG-PD6722)
RW:0	RW:00		RW:0	RW:0	RW:0	RW:0	R:X W:0

<sup>a</sup> On some versions of the VG-PD6722, this bit can be used to read levels of the A\_GPSTB and B\_GPSTB pins. Contact Amphus for more information.

#### Bit 0 — 5 V Detect (CL-PD6710 only)

0	3.3 V card detected.
1	Old or 5 V card detected.

This bit is connected to pins VS1 and VS2. Cards that will only operate at 3.3 V will drive this bit to '0'.

#### Bit 1 — V<sub>CC</sub> 3.3V

0	-VCC_5 activated when card power is to be applied.
1	-VCC_3 activated when card power is to be applied.

This bit determines which output pin is to be used to enable V<sub>CC</sub> power to the socket when card power is to be applied; it is used in conjunction with bits 5:4 of the **Power Control** register (see page 32).

#### Bit 2 — Pulse Management Interrupt

0	Card status change management interrupts are passed to the appropriate IRQ[XX] or -INTR pin as level-sensitive.
1	When a card status change management interrupt occurs, the appropriate IRQ[XX] or -INTR pin is driven with the pulse train shown in Figure 8-1 and allows for interrupt sharing.

This bit selects Level or Pulse mode operation of the IRQ[XX] or -INTR pin being used for card status change management interrupts (see page 16). Note that a clock must be present on the incoming CLK for pulsed interrupts to work.

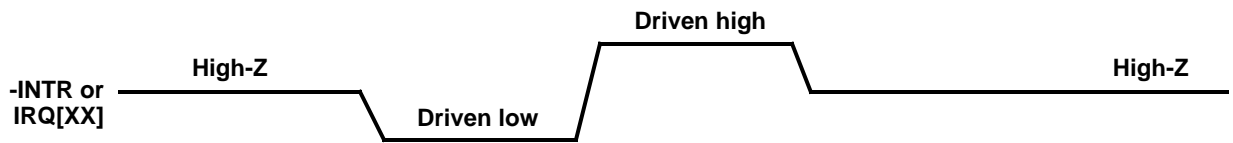

**Figure 8-1. Pulse Mode Interrupts**

**Bit 3 — Pulse System IRQ**

0	RDY/-IREQ generated interrupts are passed to the IRQ[XX] pin as level-sensitive.
1	When a RDY/-IREQ interrupt occurs, the IRQ[XX] pin is driven with the pulse train shown in Figure 8-1 and allows for interrupt sharing.

This bit selects Level or Pulse mode operation of the IRQ[XX] pins for interrupts from a PC Card RDY/-IREQ pin (see page 19).

**Bit 4 — Speaker Enable**

0	SPKR_OUT* is high-impedance.
1	SPKR_OUT* is driven from the XOR of -SPKR from each enabled socket.

This bit determines whether the card -SPKR pin will drive SPKR\_OUT\* (see page 17).

**Bit 7 — Inpack Enable**

0	-INPACK pin (see page 19) ignored.
1	-INPACK pin used to control data bus drivers during I/O read from the socket.

This bit is used to determine when to drive data onto the ISA bus.



## 8.2 FIFO Control

<i>Register Name:</i> <b>FIFO Control</b>				<i>Register Per:</i> socket			
<i>Index:</i> <b>17h</b>				<i>Register Compatibility Type:</i> ext.			
<i>Bit 7</i>	<i>Bit 6</i>	<i>Bit 5</i>	<i>Bit 4</i>	<i>Bit 3</i>	<i>Bit 2</i>	<i>Bit 1</i>	<i>Bit 0</i>
Empty Write FIFO	<i>Scratchpad Bits<sup>a</sup></i>						
RW	RW:0000000						

<sup>a</sup> Because a write will flush the FIFO, these scratchpad bits should be used only when card activity is guaranteed not to occur.

### Bit 7 — Empty Write FIFO

Value	I/O Read	I/O Write
0	FIFO not empty	No operation occurs; default on reset
1	FIFO empty	Flush the FIFO

This bit controls FIFO operation and reports FIFO status. When this bit is written to '1', all data in the FIFO is lost. During read operations when this bit is '1', the FIFO is empty. During read operations when this bit is '0', data is still in the FIFO. This bit is used to ensure the FIFO is empty before changing timing registers.

FIFO contents will be lost whenever any of the following occur:

- 1 PWRGOOD pin (see page 14) is '0'.
- 1 The card is removed.
- 1 V<sub>CC</sub> Power bit (see page 33) is programmed to '0'.



### 8.3 Misc Control 2

<i>Register Name: Misc Control 2</i>						<i>Register Per: chip</i>	
<i>Index: 1Eh</i>						<i>Register Compatibility Type: ext.</i>	
<i>Bit 7</i>	<i>Bit 6</i>	<i>Bit 5</i>	<i>Bit 4</i>	<i>Bit 3</i>	<i>Bit 2</i>	<i>Bit 1</i>	<i>Bit 0</i>
IRQ15 Is RI Out	DMA System (VG-PD6722)	Three-State Bit 7	Drive LED Enable	5V Core	Suspend	Low-Power Dynamic Mode	Bypass Frequency Synthesizer
RW:0	RW:0	RW:0	RW:0	RW:0	RW:0	RW:1	RW:0

#### Bit 0 — Bypass Frequency Synthesizer

0	Normal operation, internal clock = CLK input frequency x 7/4.
1	Internal clock = CLK input frequency (see page 17).

This bit determines internal time base.

#### Bit 1 — Low-Power Dynamic Mode

0	Clock runs always.
1	Normal operation, stop clock when possible.

This bit determines whether Low-Power Dynamic mode is enabled. For maximum operational power savings, keep this bit set to '1'.

#### Bit 2 — Suspend

0	Normal operation.
1	Stop Frequency Synthesizer, enable all Low-Power modes and disable socket access.

This bit enables Suspend mode. After entering Suspend, AEN should be pulled high for lowest power consumption. When this bit is high and AEN is high, all ISA bus interface inputs are turned off. In 82386SL systems when the processor is in Suspend mode, the ISA bus interface signals float; this feature will prevent high current flow in the VG-PD67XX inputs.

#### Bit 3 — 5V Core

0	Normal operation: use when CORE_VDD pin is connected to 3.3 volts.
1	Selects input thresholds for use when 5.0 volts is connected to the VG-PD67XX CORE_VDD pins.

This bit selects input threshold circuits for use when 3.3 or 5.0 volts is connected to the VG-PD67XX CORE\_VDD pins. This bit must be set to '0' when the CORE\_VDD pins are connected to 3.3 volts to preserve TTL-compatible input thresholds to the card socket.

#### Bit 4 — Drive LED Enable

0	IRQ12 operates normally.
1	IRQ12 becomes an open-drain output suitable for driving an LED (driven whenever the card -SPKR output is turned on, and the corresponding Speaker Is LED input bit (see page 56) is set).

**NOTE:**This bit should be set to '0' if in Memory Card Interface mode.

This bit determines whether -SPKR is used to drive an LED on the IRQ12 (see page 16) for disk drives.



**Bit 5 — Three-State Bit 7**

0	Normal operation.
1	For socket I/O at address 03F7h and 0377h, do not drive bit 7.

This bit enables floppy change bit compatibility.

**Bit 6 — DMA System (VG-PD6722 only)**

0	Configured for non-DMA mode on the VG-PD6722.
1	Configured for DMA mode on the VG-PD6722.

On the CL-PD6710, this bit is reserved.

On the VG-PD6722, this bit is used to configure system interface signals for normal or DMA operation. At reset, the signals IRQ9, IRQ10, and -VPP\_VALID are in non-DMA mode, and this bit is set to '0'. When this bit is set to '1', the IRQ9, IRQ10, and -VPP\_VALID pins are reconfigured for system bus DMA interfacing. Refer to Chapter 13 for a functional description of these pins during DMA operation.

**Bit 7 — IRQ15 Is RI Out**

0	Normal IRQ15 operation.
1	IRQ15 is connected to Ring Indicate pin on the host processor.

This bit determines the function of the IRQ15 pin. When configured for ring indicate, IRQ15 is used to resume a processor with NMI or SMI such as an 82486SL when a high-to-low change is detected on the -STSCHG pin.





## 8.4 Chip Information

<i>Register Name:</i> <b>Chip Information</b>						<i>Register Per:</i> chip	
<i>Index:</i> <b>1Fh</b>						<i>Register Compatibility Type:</i> ext.	
<i>Bit 7</i>	<i>Bit 6</i>	<i>Bit 5</i>	<i>Bit 4</i>	<i>Bit 3</i>	<i>Bit 2</i>	<i>Bit 1</i>	<i>Bit 0</i>
Host-Adapter Identification		Dual/Single Socket*	VG-PD67XX Revision Level			Reserved	
R:11		R:n <sup>a</sup>	R:nnnn <sup>b</sup>			R:n <sup>c</sup>	

<sup>a</sup> The value for CL-PD6710 is '0', and the value for VG-PD6722 is '1'.

<sup>b</sup> This read-only value depends on the revision level of the VG-PD67XX chip.

<sup>c</sup> The value for VG-PD6722 is '1'. The value for the CL-PD6710 is '0'.

### Bits 4:1 — VG-PD67XX Revision Level

This field identifies the revision of the controller. The initial value is '111'. Contact for more information on revision levels for the CL-PD6710 and VG-PD6722.

### Bit 5 — Dual/Single Socket\*

0	Chip identified as a single-socket controller.
1	Chip identified as a dual-socket controller.

This bit specifies the number of sockets supported by the VG-PD67XX.

### Bits 7:6 — Host-Adapter Identification

00	Second read after I/O write to this register.
11	First read after I/O write to this register.

This field identifies a host-adapter device. After chip reset or doing an I/O write to this register, the first read of this register will return '11'. On the next read, this field will be '00'. This pattern of toggling data on subsequent reads can be used by software to determine presence of a host adapter in a system or to determine occurrence of a device reset.



## 8.5 ATA Control

<i>Register Name:</i> <b>ATA Control</b>					<i>Register Per:</i> socket		
<i>Index:</i> <b>26h</b>					<i>Register Compatibility Type:</i> ext.		
<i>Bit 7</i>	<i>Bit 6</i>	<i>Bit 5</i>	<i>Bit 4</i>	<i>Bit 3</i>	<i>Bit 2</i>	<i>Bit 1</i>	<i>Bit 0</i>
A25/CSEL	A24/M/S*	A23/VU	A22	A21	Scratchpad Bit	Speaker Is LED Input	ATA Mode
RW:0	RW:0	RW:0	RW:0	RW:0	RW:0	RW:0	RW:0

### Bit 0 — ATA Mode

0	Normal operation.
1	Configures the socket interface to handle ATA-type disk drives.

This bit reconfigures the particular socket as an ATA drive interface. Refer to Table 10-1 on page 67 for PC Card socket pin definitions in ATA mode.

### Bit 1 — Speaker Is LED Input

0	Normal operation.
1	The PC Card -SPKR pin will be used to drive IRQ12 if Drive LED Enable (see page 53) is set.

This bit changes the function of the BVD2/-SPKR/-LED pin (see page 20) from digital speaker input to disk status LED input. When in I/O Card Interface mode or ATA mode, setting this bit to '1' reconfigures the BVD2/-SPKR/-LED input pin to serve as a -LED input from the socket.

**NOTE:** This bit should be set to '0' if in Memory Card Interface mode.

### Bit 3 — A21

In ATA mode, the value in this bit is applied to the ATA A21 pin and is vendor-specific. Certain ATA drive vendor-specific performance enhancements beyond the PC Card Standard may be controlled through use of this bit. This bit has no hardware control function when not in ATA mode.

### Bit 4 — A22

In ATA mode, the value in this bit is applied to the ATA A22 pin and is vendor-specific. Certain ATA drive vendor-specific performance enhancements beyond the PC Card Standard may be controlled through use of this bit. This bit has no hardware control function when not in ATA mode.

### Bit 5 — A23/VU

In ATA mode, the value in this bit is applied to the ATA A23 pin and is vendor-specific. Certain ATA drive vendor-specific performance enhancements beyond the PC Card Standard may be controlled through use of this bit. This bit has no hardware control function when not in ATA mode.

### Bit 6 — A24/M/S\*

In ATA mode, the value in this bit is applied to the ATA A24 pin and is vendor-specific. Certain ATA drive vendor-specific performance enhancements beyond the PC Card Standard may be controlled through use of this bit. This bit has no hardware control function when not in ATA mode.

### Bit 7 — A25/CSEL

In ATA mode, the value in this bit is applied to the ATA A25 pin and is vendor-specific. Certain ATA drive vendor-specific performance enhancements beyond the PC Card Standard may be controlled through use of this bit. This bit has no hardware control function when not in ATA mode.



## 8.6 Extended Index

<i>Register Name:</i> <b>Extended Index</b>				<i>Register Per:</i> socket			
<i>Index:</i> <b>2Eh</b>				<i>Register Compatibility Type:</i> ext.			
<i>Bit 7</i>	<i>Bit 6</i>	<i>Bit 5</i>	<i>Bit 4</i>	<i>Bit 3</i>	<i>Bit 2</i>	<i>Bit 1</i>	<i>Bit 0</i>
Extended Index							
RW:00000000							

In the VG-PD6722 only, this register controls which of the following registers at index 2Fh can be accessed:

Register Name at Index 2Fh	Extended Register Index
<i>Scratchpad</i>	00h
Data Mask 0	01h
Data Mask 1	02h
Extension Control 1 (formerly named DMA Control)	03h
Maximum DMA Acknowledge Delay	04h
<i>Reserved</i>	05h–09h
External Data	0Ah
Extension Control 2	0Bh

## 8.7 Extended Data

<i>Register Name:</i> <b>Extended Data</b>				<i>Register Per:</i> socket			
<i>Index:</i> <b>2Fh</b>				<i>Register Compatibility Type:</i> ext.			
<i>Bit 7</i>	<i>Bit 6</i>	<i>Bit 5</i>	<i>Bit 4</i>	<i>Bit 3</i>	<i>Bit 2</i>	<i>Bit 1</i>	<i>Bit 0</i>
Extended Data							

The data in this register allows the registers indicated by the **Extended Index** register to be read and written. The value of this register is the value of the register selected by the **Extended Index** register.



### 8.7.1 Data Mask 0–1

<i>Register Name:</i> <b>Data Mask 0–1</b>				<i>Register Per:</i> socket			
<i>Index:</i> <b>2Fh</b>				<i>Extended Index:</i> <b>01h, 02h</b>		<i>Register Compatibility Type:</i> ext.	
<i>Bit 7</i>	<i>Bit 6</i>	<i>Bit 5</i>	<i>Bit 4</i>	<i>Bit 3</i>	<i>Bit 2</i>	<i>Bit 1</i>	<i>Bit 0</i>
Data Mask Select 0–1							
RW:00000000							

**Data Mask 0** is the mask register for I/O Map 0. For each bit set in the Data Mask Select 0 field, the corresponding data bit will not be driven when the host addresses PC Card I/O addresses in the I/O Map 0 range. If this register is set to 00h, then all data bits will be driven from the PC Card to the ISA bus (this is the reset condition). If any bits are set to ‘1’, accesses to the I/O Map 0 range of I/O on the PC Card will be forced to 8-bit operation on the ISA side. If, for example, I/O Map 0 registers are set for the range 3F7h to 3F7h, I/O Map 1 registers are set for the range 3F0h to 3F6h, Data Mask Select 0 is set to 7Fh, and a floppy drive is the PC Card device, then the conflict between the floppy address 3F7h and the hard disk register at 3F7h would not cause a conflict on the ISA bus — the floppy change bit would be correctly presented to the host.

The **Data Mask 1** register operates the same as the **Data Mask 0** register but acts on I/O addresses in the range indicated by the I/O Map 1 registers.

### 8.7.2 Extension Control 1 (VG-PD6722 only, formerly DMA Control)

<i>Register Name:</i> <b>Extension Control 1</b>				<i>Register Per:</i> socket				
<i>Index:</i> <b>2Fh</b>				<i>Extended Index:</i> <b>03h</b>		<i>Register Compatibility Type:</i> ext.		
<i>Bit 7</i>	<i>Bit 6</i>	<i>Bit 5</i>	<i>Bit 4</i>	<i>Bit 3</i>	<i>Bit 2</i>	<i>Bit 1</i>	<i>Bit 0</i>	
DMA Enable (VG-PD6722)		Pull-up Control		<i>Reserved</i>		LED Activity Enable	Auto Power Clear Disable	V <sub>CC</sub> Power Lock
RW:00		RW:0		RW:00		RW:0	RW:0	RW:0

#### Bit 0 — V<sub>CC</sub> Power Lock

0	The V <sub>CC</sub> Power bit (bit 4 of <b>Power Control</b> register) is not locked.
1	The V <sub>CC</sub> Power bit (bit 4 of <b>Power Control</b> register) cannot be changed by software.

This bit can be used to prevent card drivers from overriding the Socket Services’ task of controlling power to the card, thus preventing situations where cards are powered incorrectly.

#### Bit 1 — Auto Power Clear Disable

0	The V <sub>CC</sub> Power bit (bit 4 of <b>Power Control</b> register) is reset to ‘0’ when the card is removed.
1	The V <sub>CC</sub> Power bit (bit 4 of <b>Power Control</b> register) is not affected by card removal.

#### Bit 2 — LED Activity Enable

0	LED activity disabled.
1	LED activity enabled.

This bit allows the LED\_OUT\* pin to reflect any activity in the card. Whenever PC Card cycles are in process to or from a card in either socket, LED\_OUT\* will be active (low).



**Bit 5 — Pull-up Control**

0	Pull-ups on CD2, CD1, A_GPSTB, and B_GPSTB (VG-PD6722) are in use.
1	Pull-ups on CD2, CD1, A_GPSTB, and B_GPSTB (VG-PD6722) are turned off.

This bit turns off the pull-ups on CD2, CD1, and A\_GPSTB and B\_GPSTB (VG-PD6722). Turning off these pull-ups can be used in addition to Suspend mode to even further reduce power when cards are inserted but no card accessibility is required. Even though power may or may not still be applied, all pull-ups and their associated inputs will be disabled.

**Bit 7:6 — DMA Enable (VG-PD6722 only)**

On the VG-PD6722, DMA Enable bits 6 and 7 enable the DMA operation of the PC Card socket. At reset these bits are set to '0', and this is non-DMA mode. If either or both of these bits is set, the socket is in DMA mode. The three codes that cause DMA mode also select the use of one of three pins for the active-low -DREQ input at the PC Card interface.

Bit 7	Bit 6	Pin Used
0	1	-INPACK
1	0	WP/-IOIS16
1	1	BVD2/-SPKR

For cards requiring DMA services but also needing input acknowledge functionality, or needing to indicate the size of I/O registers within a window, or needing digital speaker or LED operation, the selection of the -DREQ signal to the socket is made to be as flexible as possible.

**8.7.3 Maximum DMA Acknowledge Delay (VG-PD6722 only)**

Register Name: <b>Maximum DMA Acknowledge Delay</b>				Register Per: socket			
Index: <b>2Fh</b>				Extended Index: <b>04h</b>			
				Register Compatibility Type: ext.			
Bit 7	Bit 6	Bit 5	Bit 4	Bit 3	Bit 2	Bit 1	Bit 0
Maximum DMA Acknowledge Delay							
RW:00000000							

During a DMA data transfer process, an ISA-based system typically follows its issuance of a DMA acknowledge with a DMA read or write cycle. However, during a DMA write-verify operation, a system can issue a DMA acknowledge without following it with a DMA read or write cycle. Because a DMA-capable PC Card receives DMA acknowledgment only by reception of a DMA read or write cycle, conditions may occur where the card never receives a DMA acknowledge. To prevent this from happening in an ISA-based system, a maximum DMA acknowledge delay feature has been added that generates a 'dummy' DMA write cycle (reads DMA data from the card) if there are no system-generated DMA read or write cycles to the card within a programmable time.

Once a DMA acknowledge is received from the system, the VG-PD6722 starts counting the time from the assertion of the DACK\* signal until the system issues a DMA read or write command (IOR\* or IOW\*). If this interval exceeds the programmed time, the VG-PD6722 assumes that a system write-verify is in progress and generates a dummy DMA write cycle at the PC Card interface. This allows the passing of the DMA acknowledge (and terminal count status) to the card so it can perform any intended verify-cycle functions.

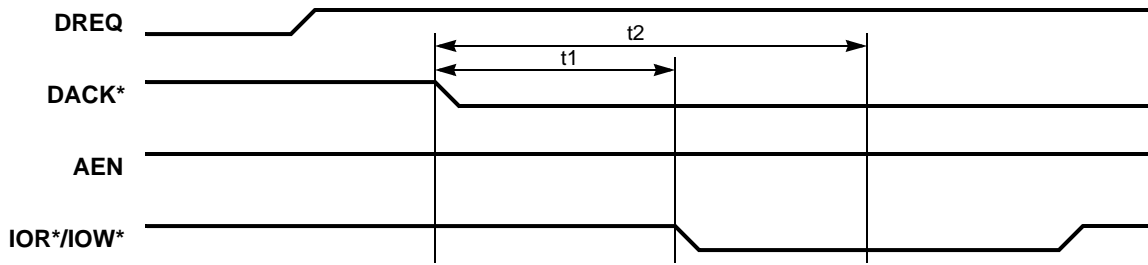

t1 = time delay from DMA acknowledge to IOR\* or IOW\* command (specified by system design).  
t2 = time to program into the Maximum DMA Acknowledge Delay register for when IOR\* or IOW\* falling edge does not occur (t2 > t1).

**Figure 8-2. Selection of Acknowledge Time-out Interval**

The maximum DMA acknowledge delay (t2 as shown in Figure 8-2) should be programmed to a time greater than the maximum time required from the system's issuance of a DMA acknowledge to its issuance of a DMA read or write cycle (t1 as shown in Figure 8-2). The t1 time is indicated in the specifications for the systems DMA cycle timing.

Typical system specifications for t1 are 190–270 ns, making a value of 80h for the **Maximum DMA Acknowledge Delay** register suitable for many applications. If the VG-PD6722 is used in an add-in card application, a value of 20h may be suitable. Table 8-1 shows **Maximum DMA Acknowledge Delay** register values to be programmed for a desired maximum DMA acknowledge delay.

**Table 8-1. Maximum DMA Acknowledge Delay Register Values**

Register Value	Maximum DMA Acknowledge Delay (25-MHz internal clock and default Setup timing)
80h	7 clocks = 280 ns
40h	8 clocks = 320 ns
C0h	9 clocks = 360 ns
20h	10 clocks = 400 ns
A0h	11 clocks = 440 ns
60h	12 clocks = 480 ns
E0h	13 clocks = 520 ns
10h	14 clocks = 560 ns
90h	15 clocks = 600 ns
50h	16 clocks = 640 ns
D0h	17 clocks = 680 ns
30h	18 clocks = 720 ns
B0h	19 clocks = 760 ns



**8.7.4 External Data (VG-PD6722 only, Socket A, Index 2Fh)**

<i>Register Name: External Data</i>				<i>Register Per: socket</i>			
<i>Index: 2Fh only</i>				<i>Extended Index: 0Ah</i>		<i>Register Compatibility Type: ext.</i>	
<i>Bit 7</i>	<i>Bit 6</i>	<i>Bit 5</i>	<i>Bit 4</i>	<i>Bit 3</i>	<i>Bit 2</i>	<i>Bit 1</i>	<i>Bit 0</i>
External Data 7	External Data 6	External Data 5	External Data 4	External Data 3	External Data 2	External Data 1	External Data 0
RW:0	RW:0	RW:0	RW:0	RW:0	RW:0	RW:0	RW:0

**Bits 7:0 — External Data**

This register is updated and accessed according to the setting of bits 3 and 4 of the Socket A **Extension Control 2** register (Index 2Fh, Extended Index 0Bh).

**Table 8-2. Functions of Socket A External Data Register**

Socket A Extension Control 2		Function of Socket A External Data Register
Bit 4: GPSTB on IOW*	Bit 3: GPSTB on IOR*	
0	0	Scratchpad
0	1	External read port: A_GPSTB is a read buffer enable for external data on SD[15:8]
1	0	External write port: A_GPSTB is a write latch enable for SD[15:8] to get latched to an external register. Reads of Socket A External Data register produce the value written to the latch.
1	1	Reserved

**NOTE:** For software compatibility of external data access across the PC Card host adapter product line, the Socket A **External Data** register should only be used as a *write* port and not as a *read* port. Also for compatibility, only the lower nibble of **External Data** should be accessed and the upper nibble should be ignored.

Refer to Chapter 11 for more information on the use of the **External Data** register.



### 8.7.5 External Data (VG-PD6722 only, Socket A, Index 6Fh)

<i>Register Name: External Data</i>				<i>Register Per: socket</i>							
<i>Index: 6Fh only</i>				<i>Extended Index: 0Ah</i>				<i>Register Compatibility Type: ext.</i>			
<i>Bit 7</i>	<i>Bit 6</i>	<i>Bit 5</i>	<i>Bit 4</i>	<i>Bit 3</i>	<i>Bit 2</i>	<i>Bit 1</i>	<i>Bit 0</i>				
External Data 7	External Data 6	External Data 5	External Data 4	External Data 3 or B_VS2# Input	External Data 2 or B_VS1# Input	External Data 1 or A_VS2# Input	External Data 0 or A_VS1# Input				
RW:0	RW:0	RW:0	RW:0	R:0	R:0	R:0	R:0				

#### Bits 7:0 — External Data

This register is updated and accessed according to the setting of bits 3 and 4 of the Socket B **Extension Control 2** register (Index 6Fh, Extended Index 0Bh).

**Table 8-3. Functions of Socket B External Data Register (VG-PD6722 only)**

Socket B Extension Control 2		Function of Socket B External Data Register
Bit 4: GPSTB on IOW*	Bit 3: GPSTB on IOR*	
0	0	Bits 7:4 — scratchpad Bits 3:2 — Socket B VS2# and VS1# levels (VG-PD6722 only) Bits 1:0 — Socket A VS2# and VS1# levels
0	1	External read port: B_GPSTB is a read buffer enable for external data on SD[15:8].
1	0	External write port: B_GPSTB is a write latch enable for SD[15:8] to get latched to an external register. Reads of Socket B External Data register produce the value written to the latch.
1	1	Reserved

**NOTE:** For software compatibility of external data access across the PC Card host adapter product line, the Socket B **External Data** register should only be used as a *read* port and not as a *write* port. Also for compatibility, only the lower nibble of **External Data** should be accessed and the upper nibble should be ignored. For software compatibility with VS1# and VS2# detection software, when Socket B is used as a read port, socket VS1# and VS2# signals should be connected to the external read buffer as shown in Figure 12-1 on page 74.

Refer to Chapter 11 for more information on the use of the **External Data** register, and Chapter 12 for more information on VS1# and VS2# detection.





**8.7.6 Extension Control 2 (VG-PD6722 only)**

<i>Register Name: Extension Control 2</i>				<i>Register Per: socket</i>			
<i>Index: 2Fh</i>		<i>Extended Index: 0Bh</i>		<i>Register Compatibility Type: ext.</i>			
<i>Bit 7</i>	<i>Bit 6</i>	<i>Bit 5</i>	<i>Bit 4</i>	<i>Bit 3</i>	<i>Bit 2</i>	<i>Bit 1</i>	<i>Bit 0</i>
Reserved		Active-high GPSTB	GPSTB on IOW*	GPSTB on IOR*	Totem-pole GPSTB	Reserved	
RW:00		RW:0	RW:0	RW:0	RW:0	RW:00	

**Bit 5 — Active-high GPSTB**

0	GPSTB outputs are active-low.
1	GPSTB outputs are active-high.

**Bit 4 — GPSTB on IOW\* (VG-PD6722 only)**

0	A_GPSTB (VG-PD6722) pins are used as voltage sense.
1	A_GPSTB (VG-PD6722) pins are used to strobe I/O writes on SD[15:8].

Note that setting this bit forces the pull-ups on A\_GPSTB (VG-PD6722) to be off, independent of the setting of the Pull-Up Control bit (index 2Fh, extended index 03h, bit 5). See Section 8.7.5, Chapter 11, and Chapter 12.

**Bit 3 — GPSTB on IOR\* (VG-PD6722 only)**

0	B_GPSTB (VG-PD6722) pins (socket B) are used as voltage sense.
1	B_GPSTB (VG-PD6722) pins are used to strobe I/O reads on SD[15:8].

Note that setting this bit forces the pull-ups on B\_GPSTB (VG-PD6722) to be off, independent of the setting of the Pull-Up Control bit (index 6Fh, extended index 03h, bit 5). See Section 8.7.5, Chapter 11, and Chapter 12.

**Bit 2 — Totem-pole GPSTB**

0	GPSTB outputs are open-collector.
1	GPSTB outputs are totem-pole.

When GPSTB outputs are totem-pole, their 'high' level is driven to the level of the +5V pin, instead of high-impedance.



## 9. TIMING REGISTERS

The following information about the timing registers is important:

- 1 All timing registers take effect immediately and should only be changed when the FIFO is empty (see the **FIFO Control** register on page 52).
- 1 Selection of Timing 0 or Timing 1 register sets is controlled by **I/O Window Control**, bit 3 and/or bit 7 (see page 41).

### 9.1 Setup Timing 0–1

<i>Register Name:</i> <b>Setup Timing 0–1</b>				<i>Register Per:</i> socket			
<i>Index:</i> <b>3Ah, 3Dh</b>				<i>Register Compatibility Type:</i> 365			
Bit 7	Bit 6	Bit 5	Bit 4	Bit 3	Bit 2	Bit 1	Bit 0
Setup Prescalar Select			Setup Multiplier Value				
RW:00			RW:000001				

There are two separate Setup Timing registers, each with identical fields. These registers are located at the following indexes:

Index	Setup Timing
3Ah	Setup Timing 0
3Dh	Setup Timing 1

The Setup Timing register for each timing set controls how long a PC Card cycle's command (that is, -OE, -WE, -IORD, -IOWR; see page 18) setup will be, in terms of the number of internal clock cycles.

The overall command setup number of clocks  $S$  is programmed by selecting a 2-bit prescaling value (bits 7:6 of this register) representing weights of 1, 16, 256, or 8192, and then selecting a multiplier value (bits 5:0) to which that prescalar is multiplied to produce the overall command setup timing length according to the following formula:

$$S = (N_{pres} \times N_{val}) + 1 \tag{Equation 9-1}$$

The value of  $S$ , representing the number of internal clock cycles for command setup, is then multiplied by the internal clock's period to determine the command setup time (see Section 14.3.6 for further discussion).

#### Bits 5:0 — Setup Multiplier Value

This field indicates an integer value  $N_{val}$  from 0 to 63; it is combined with a prescalar value (bits 7:6) to control the length of setup time before a command becomes active.

#### Bits 7:6 — Setup Prescalar Select

00	$N_{pres} = 1$
01	$N_{pres} = 16$
10	$N_{pres} = 256$
11	$N_{pres} = 8192$

This field chooses one of four prescalar values  $N_{pres}$  that are combined with the value of the Setup Multiplier Value (bits 5:0) to control the length of setup time before a command becomes active.



## 9.2 Command Timing 0–1

Register Name: <b>Command Timing 0–1</b>				Register Per: socket			
Index: <b>3Bh, 3Eh</b>				Register Compatibility Type: 365			
Bit 7	Bit 6	Bit 5	Bit 4	Bit 3	Bit 2	Bit 1	Bit 0
Command Prescalar Select		Command Multiplier Value					
RW:00		RW:000110/001111 <sup>a</sup>					

<sup>a</sup> Timing set 0 (index 3Bh) resets to 06h for socket timing equal to standard AT-bus-based cycle times. Timing set 1 (3Eh) resets to 0Fh for socket timings equal to standard AT-bus timing using one additional wait state.

There are two separate Command Timing registers, each with identical fields. These registers are located at the following indexes:

Index	Command Timing
3Bh	Command Timing 0
3Eh	Command Timing 1

The Command Timing register for each timing set controls how long a PC Card cycle's command (that is, -OE, -WE, -IORD, -IOWR; see page 18) active time will be, in terms of the number of internal clock cycles.

The overall command timing length  $C$  is programmed by selecting a 2-bit prescaling value (bits 7:6 of this register) representing weights of 1, 16, 256, or 8192, and then selecting a multiplier value (bits 5:0) to which that prescalar is multiplied to produce the overall command timing length according to the following formula:

$$C = (N_{pres} \times N_{val}) + 1 \quad \text{Equation 9-2}$$

The value of  $C$ , representing the number of internal clock cycles for a command, is then multiplied by the internal clock's period to determine the command active time (see Section 14.3.6 for further discussion).

### Bits 5:0 — Command Multiplier Value

This field indicates an integer value  $N_{val}$  from 0 to 63; it is combined with a prescalar value (bits 7:6) to control the length that a command is active.

### Bits 7:6 — Command Prescalar Select

00	$N_{pres} = 1$
01	$N_{pres} = 16$
10	$N_{pres} = 256$
11	$N_{pres} = 8192$

This field chooses one of four prescalar values  $N_{pres}$  that are combined with the value of the Command Multiplier Value (bits 5:0) to control the length that a command is active.



### 9.3 Recovery Timing 0–1

Register Name: <b>Recovery Timing 0–1</b>				Register Per: socket			
Index: <b>3Ch, 3Fh</b>				Register Compatibility Type: 365			
Bit 7	Bit 6	Bit 5	Bit 4	Bit 3	Bit 2	Bit 1	Bit 0
Recovery Prescalar Select		Recovery Multiplier Value					
RW:00		RW:000011					

There are two separate Recover Timing registers, each with identical fields. These registers are located at the following indexes:

Index	Recovery Timing
3Ch	Recovery Timing 0
3Fh	Recovery Timing 1

The Recovery Timing register for each timing set controls how long a PC Card cycle’s command (that is, -OE, -WE, -IORD, -IOWR; see page 18) recovery will be, in terms of the number of internal clock cycles.

The overall command recovery timing length  $R$  is programmed by selecting a 2-bit prescaling value (bits 7:6 of this register) representing weights of 1, 16, 256, or 8192, and then selecting a multiplier value (bits 5:0) to which that prescalar is multiplied to produce the overall command recovery timing length according to the following formula:

$$R = (N_{pres} \times N_{val}) + 1 \tag{Equation 9-3}$$

The value of  $R$ , representing the number of internal clock cycles for command recovery, is then multiplied by the internal clock’s period to determine the command recovery time (see Section 14.3.6 for further discussion).

#### Bits 5:0 — Recovery Multiplier Value

This field indicates an integer value  $N_{val}$  from 0 to 63; it is combined with a prescalar value (bits 7:6) to control the length of recovery time after a command is active.

#### Bits 7:6 — Recovery Prescalar Select

00	$N_{pres} = 1$
01	$N_{pres} = 16$
10	$N_{pres} = 256$
11	$N_{pres} = 8192$

This field chooses one of four prescalar values  $N_{pres}$  that are combined with the value of the Recovery Multiplier Value (bits 5:0) to control the length of recovery time after a command is active.



## 10. ATA MODE OPERATION

The VG-PD67XX PC Card interfaces can be dynamically configured to support a PC Card-compatible ATA disk interface (commonly known as 'IDE') instead of the standard PC Card interface. Disk drives that can be made mechanically-compatible with PC Card dimensions can thus operate through the socket using the ATA electrical interface.

Configuring a socket to support ATA operation changes the function of certain card socket signals to support the needs of the ATA disk interface. Table 10-1 lists each interface pin and its function when a VG-PD67XX card socket is operating in ATA mode. Refer to application note AN-PD5, *Configuring PCMCIA Sockets for ATA Drive Interface*, for more information.

All register functions of the VG-PD67XX are available in ATA mode, including socket power control, interface signal disabling, and card window control. No memory operations are allowed in ATA mode.

**Table 10-1. ATA Pin Cross-Reference**

PC Card Socket Pin Number	Function	
	PC Card Interface	ATA Interface
1	Ground	Ground
2	D3	D3
3	D4	D4
4	D5	D5
5	D6	D6
6	D7	D7
7	-CE1	-CS0
8	A10	n/c
9	-OE	-ATA (always low)
10	A11	n/c
11	A9	CS1*
12	A8	n/c
13	A13	n/c
14	A14	n/c
15	-WE	n/c
16	-IREQ	IREQ
17	VCC	VCC
18	VPP1	n/c
19	A16	n/c

**Table 10-1. ATA Pin Cross-Reference (cont.)**

PC Card Socket Pin Number	Function	
	PC Card Interface	ATA Interface
20	A15	n/c
21	A12	n/c
22	A7	n/c
23	A6	n/c
24	A5	n/c
25	A4	n/c
26	A3	n/c
27	A2	A2
28	A1	A1
29	A0	A0
30	D0	D0
31	D1	D1
32	D2	D2
33	-IOIS16	-IOIS16
34	Ground	Ground
35	Ground	Ground
36	-CD1	-CD1
37	D11	D11
38	D12	D12



**Table 10-1. ATA Pin Cross-Reference (cont.)**

PC Card Socket Pin Number	Function	
	PC Card Interface	ATA Interface
39	D13	D13
40	D14	D14
41	D15	D15
42	-CE2	-CS1
43	VS1	VS1
44	-IORD	-IORD
45	-IOWR	-IOWR
46	A17	n/c
47	A18	n/c
48	A19	n/c
49	A20	n/c
50	A21	n/c
51	VCC	VCC
52	VPP2	n/c
53	A22	n/c
54	A23	VU

**Table 10-1. ATA Pin Cross-Reference (cont.)**

PC Card Socket Pin Number	Function	
	PC Card Interface	ATA Interface
55	A24	-M/S
56	A25	CSEL
57	VS2	VS2
58	RESET	RESET*
59	-WAIT	IOCHRDY
60	-INPACK	DREQ <sup>a</sup>
61	-REG	-DACK <sup>a</sup>
62	-SPKR	-LED
63	-STSCHG	-PDIAG <sup>a</sup>
64	D8	D8
65	D9	D9
66	D10	D10
67	-CD2	-CD2
68	Ground	Ground

<sup>a</sup> Not supported by the VG-PD67XX.



## 11. USING GPSTB PINS FOR EXTERNAL PORT CONTROL (VG-PD6722 only)

The VG-PD6722 provides pins that can be programmed to function as general-purpose strobes to external latches or buffers, allowing them to serve as read ports or write ports mapped into the VG-PD6722 register set.

Configuring a GPSTB pin as a read port allows an easy way to read additional card status such as VS1# and VS2# levels, a card socket microswitch status, a card port cover microswitch status, card eject solenoid position status, or general system signal status.

Configuring a GPSTB pin as a write port allows an easy way to control additional features such as card-state LEDs, card mechanism solenoids, or motor eject mechanisms.

### 11.1 Control of GPSTB Pins

The **Extension Control 2** register controls the GPSTB pins.

For the VG-PD6722, the A\_GPSTB pin is controlled by the **Extension Control 2** register at Socket A (index 2Fh, extended index 0Bh), and the B\_GPSTB pin is controlled by the **Extension Control 2** register at Socket B (index 6Fh, extended index 0Bh).

The following table summarizes how the GPSTB pins are configured and how data is accessed from external ports created by using a GPSTB pin to control an external read or write port.

**Table 11-1. Registers for Control and Data of GPSTB Pins**

Pin Name	GPSTB Control Access	External Port Data Access
A_GPSTB (VG-PD6722)	Set register 2E to 0Bh, access <b>Extension Control 2</b> register at 2F	Set register 2E to 0Ah, access <b>External Data</b> register at 2F
B_GPSTB (VG-PD6722)	Set register 6E to 0Bh, access <b>Extension Control 2</b> register at 6F	Set register 6E to 0Ah, access <b>External Data</b> register at 6F

### Programming the Extension Control 2 Register

There is one **Extension Control 2** register per GPSTB pin. Each register has identical GPSTB control bits, as follows. See also the description of this register in Section 8.7.6.

<i>Register Name: <b>Extension Control 2</b></i>				<i>Register Per: socket</i>			
<i>Index: <b>2Fh and 6Fh</b></i>				<i>Extended Index: <b>0Bh</b></i>			
				<i>Register Compatibility Type: ext.</i>			
<i>Bit 7</i>	<i>Bit 6</i>	<i>Bit 5</i>	<i>Bit 4</i>	<i>Bit 3</i>	<i>Bit 2</i>	<i>Bit 1</i>	<i>Bit 0</i>
Reserved		Active-high GPSTB	GPSTB on IOW*	GPSTB on IOR*	Totem-pole GPSTB	Reserved	
RW:00		RW:0	RW:0	RW:0	RW:0	RW:00	

Bit 5 allows programming of the active level of GPSTB, with the default being active-low. Setting bit 5 to '1' causes a GPSTB output to be low normally and high (active) upon external data access.



Bit 4 controls use of the respective GPSTB pin as a write strobe for an external general-purpose latch. When the respective extended index is set to 0Ah and the index register is set to the respective 2Fh or 6Fh setting, I/O writes that access address 3E1h will result in the respective GPSTB signal being driven active for the duration of the ISA bus IOW\* signal being driven low.

Bit 3 controls use of the respective GPSTB pin as a read strobe for an external general-purpose buffer. When the respective extended index is set to 0Ah and the index register is set to the respective 2Fh or 6Fh setting, I/O reads that access address 3E1h will result in the respective GPSTB signal being driven active for the duration of the ISA bus IOR\* signal being driven low.

Bit 2 cause the GPSTB output to be totem-pole instead of the default open-collector configuration. When GPSTB outputs are totem-pole, their 'high' level is driven to the voltage of the '+5V' pin, instead of to high-impedance.

If neither bit 3 nor bit 4 is set, the respective GPSTB pin functions as a reserved input in a VG-PD6722 that is an internal pull-up to the '+5V' pin. This internal pull-up is turned off whenever the GPSTB pin is configured as a general-purpose strobe, or when the respective socket's Pull-up Control bit is set to '1'.

Bits 7:6 and 1:0 are reserved and *must* be programmed to '0'. These bits should not be used as scratch-pad bits.

**External Data Port Access through the External Data Register**

Data to be accessed from an external read or write port is mapped to the respective **External Data** register at Extended Index 0Ah. This allows external data to be accessed as if it were a register in the VG-PD67XX register set.

To achieve this mapping, the external data port's buffer or latch data connections should be made to SD[15:8] of the system bus for 16-bit systems, and to SD[7:0] of the system bus for 8-bit systems.

To support readback of data written to an external I/O port by use of a GPSTB pin, a shadow of the external data register exists, which is read when an I/O read is done from the external data register location corresponding to a GPSTB pin programmed as a write strobe.

For more information on the Socket A and Socket B versions of this register, see the description of this register in Section 8.7.4 and Section 8.7.5.

<i>Register Name:</i> <b>External Data</b>				<i>Register Per:</i> socket			
<i>Index:</i> <b>2Fh</b>		<i>Extended Index:</i> <b>0Ah</b>		<i>Register Compatibility Type:</i> ext.			
<i>Bit 7</i>	<i>Bit 6</i>	<i>Bit 5</i>	<i>Bit 4</i>	<i>Bit 3</i>	<i>Bit 2</i>	<i>Bit 1</i>	<i>Bit 0</i>
External Data 7	External Data 6	External Data 5	External Data 4	External Data 3	External Data 2	External Data 1	External Data 0
RW:0	RW:0	RW:0	RW:0	RW:0	RW:0	RW:0	RW:0



## 11.2 Example Implementations of GPSTB-Controlled Read and Write Ports

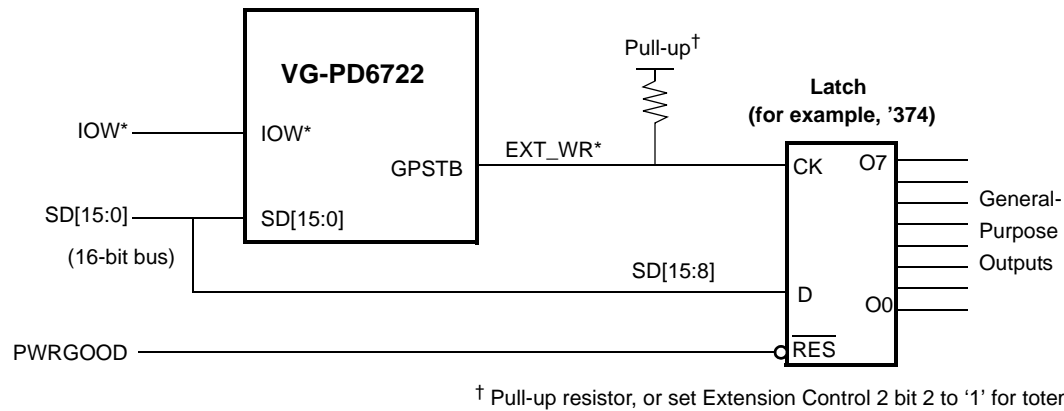
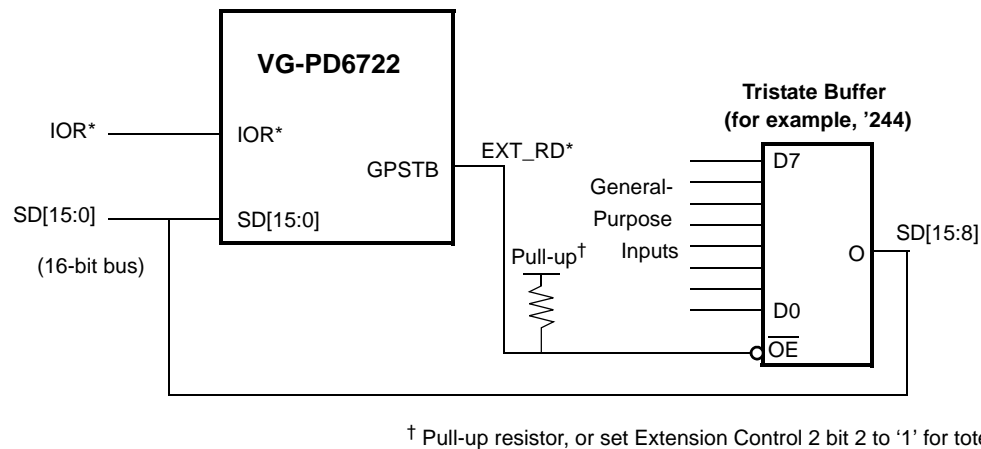

**Figure 11-1. Example GPSTB Write Port (Extension Control 2 bits 4:3 are '10')**

In this mode, **Extension Control 2** register bit 4 is set to '1' enabling the GPSTB pin to function as a write strobe. Writes to the respective extended index 0Ah cause the respective GPSTB to go active (low) for the duration of the system's IOW\* pulse.

On writes, data is written to both the external latch and the internal shadow copy of the **External Data** register. A read of the respective extended index 0Ah would produce the last value written to the latch.

Connection of the ISA bus PWRGOOD signal to the external latch ensures that the latch assumes all '0's at its outputs when the VG-PD67XX is reset.



**Figure 11-2. Example GPSTB Read Port (Extension Control 2 bits 4:3 are '01')**

In this mode, **Extension Control 2** register bit 3 is set to '1', enabling the respective GPSTB pin to function as a read strobe. Reads from the corresponding extended index 0Ah cause GPSTB to go active (default active level is low) for the duration of the system's IOR\* pulse.

**NOTE:** Data is still written to the shadowed **External Data** register on writes to Extended Index 0Ah but is not visible.



### **11.3 GPSTB in Suspend Mode**

GPSTB read and write strobes operate while the device is in suspend mode, but they are not allowed when the device is in hardware-assisted 'Super-Suspend' mode (AEN held high while in Suspend mode).

A clock to the VG-PD6722 is not required for the external signal at GPSTB to occur, but shadowing of write values in the internal register at Extended Index 0Ah requires that the VG-PD67XX is not in Suspend mode so there is an active internal clock for register writes.



## 12. VS1# AND VS2# VOLTAGE DETECTION

The VG-PD6722 provides support for VS1# and VS2# voltage sense for environments where special low-voltage keyed PC Card sockets are to be used. With a low-voltage keyed socket, it is necessary to determine the operating voltage range of a card before applying power to it. The VG-PD6722 supports reading of the levels on a socket's VS1# and VS2# pins through a uniform extended register programming model using Socket B extended register 0Ah. The programming model is as follows:

<i>Register Name: External Data</i>				<i>Register Per: socket</i>			
<i>Index: 6Fh</i>				<i>Extended Index: 0Ah</i>		<i>Register Compatibility Type: ext.</i>	
<i>Bit 7</i>	<i>Bit 6</i>	<i>Bit 5</i>	<i>Bit 4</i>	<i>Bit 3</i>	<i>Bit 2</i>	<i>Bit 1</i>	<i>Bit 0</i>
External Data 7	External Data 6	External Data 5	External Data 4	B_VS2 Input	B_VS1 Input	A_VS2 Input	A_VS1 Input
RW:0	RW:0	RW:0	RW:0	R:0	R:0	R:0	R:0

For voltage detection on the CL-PD6710, refer to the 5V\_DET pin.



On the VG-PD6722, the B\_GPSTB pin is programmed as a general-purpose read strobe. The VS1# and VS2# pins from the A and B sockets are connected to the external half of a '244 buffer as follows (which allows Socket A VS1 and VS2 to appear as bits 0 and 1, and Socket B VS1 and VS2 to appear as bits 2 and 3):

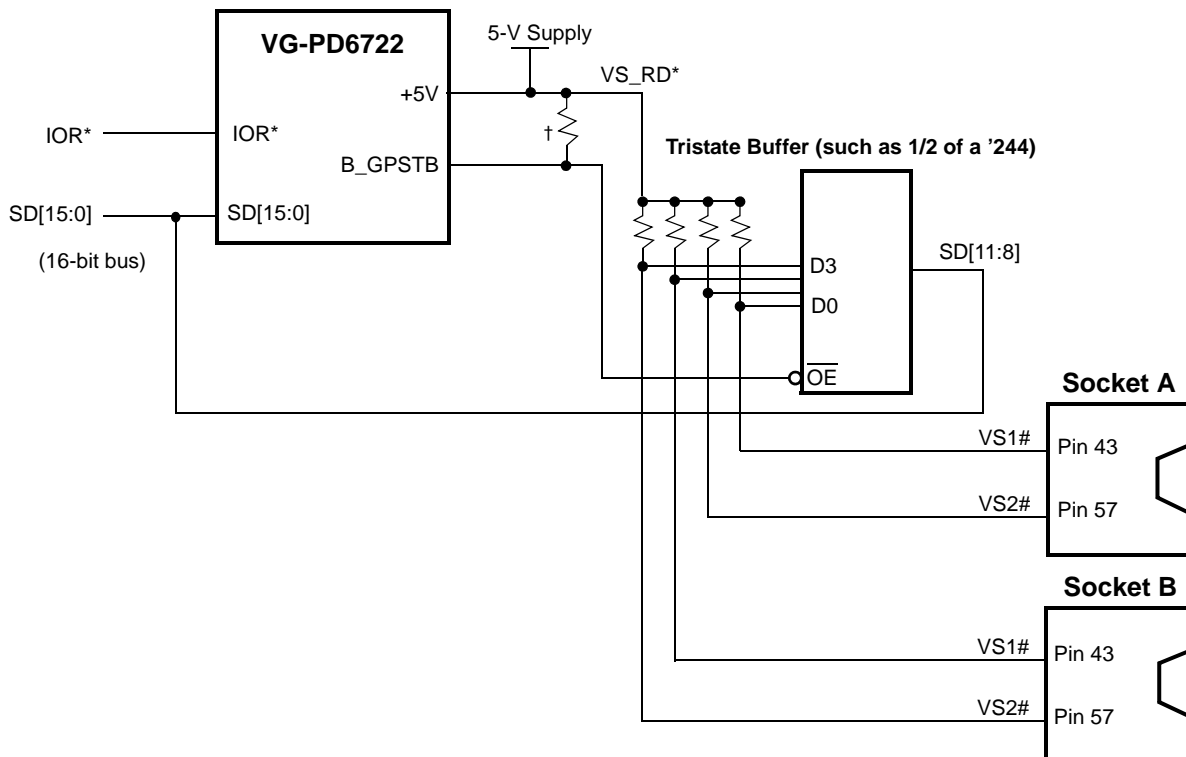

† Pull-up resistor, or set Extension Control 2 bit 2 to '1' for totem-pole output.

**Figure 12-1. VS1# and VS2# Sensing on a VG-PD6722  
(Socket B Extension Control 2 bit 3 is '1')**



## 13. DMA OPERATION (VG-PD6722 only)

### 13.1 DMA Capabilities of the VG-PD6722

The VG-PD6722 include support of a DMA-capable PC Card slave and the movement of DMA data to/from the card with the ISA bus as a DMA master.

Only one socket at a time should be enabled for DMA transfer because the ISA bus DMA handshake signals are shared between both socket interfaces.

DMA transfers to and from the DMA-capable PC Card may be 8- or 16-bit, as indicated by the size of the ISA bus DMA cycle.<sup>1</sup>

### 13.2 DMA-Type PC Card Cycles

Transfer of DMA data to or from a card is achieved through use of a special DMA-type PC Card interface cycle. This cycle is defined to not conflict with standard PC Card memory or I/O cycles.

A card that is DMA-capable can distinguish PC Card interface cycle types presented by the VG-PD6722 according to the following table:

**Table 13-1. Four Card Cycle Types for DMA-Type PC Card Interface**

Socket Interface Cycle Type	Function of -WE/-OE	Function of -IORD/-IOWR	Function of -REG
Card Memory Read/Write	Data transfer signaling	Always inactive high	Always inactive high
Attribute Memory Read/Write	Data transfer signaling	Always inactive high	Always low
Card I/O Read/Write	Always inactive high	Data transfer signaling	Low = non-DMA I/O cycle
Card DMA Data Read/Write	Terminal count outputs	Data transfer signaling	High = DMA cycle

**NOTE:** Bits 7 and 6 of the **Extension Control 1** register must be nonzero for Table 13-1 to be true; otherwise only standard PC Card cycles will be issued to the card.

The PC Card address is also undefined during the DMA read or write cycle.

Card DMA data read and write cycles transfer DMA data to or from a DMA-capable PC Card. These cycles are distinguished from normal card I/O cycles by the -REG signal being high during the cycle, which is an undefined condition in the PC Card Standard.

<sup>1</sup> Transfer size at socket interface is the same as transfer size on an ISA bus. For 8-bit DMA transfers, connect VG-PD6722 DMA handshake signals to ISA bus DMA channels 0, 1, 2, or 3. For 16-bit transfers, connect VG-PD6722 DMA handshake signals to ISA bus DMA channels 5, 6, or 7.

### 13.3 ISA Bus DMA Handshake Signal

A DMA request from the card is passed to the ISA bus as long as the socket interface FIFO is empty. IRQ10 is used as the DMA request output to the ISA bus when bit 2 of the **Misc Control 2** register is '1'. When bit 2 of the **Misc Control 2** register is '1', IRQ9 is redefined as the active-low DMA acknowledge input from the ISA bus. This signal must remain active for all DMA transfers through the VG-PD6722.

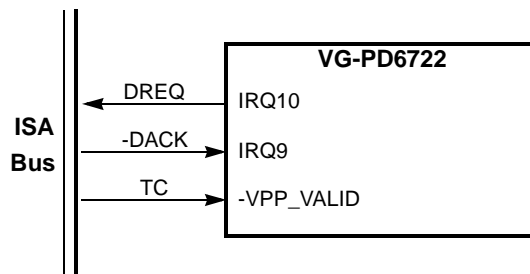

**Figure 13-1. DMA Handshake Connections to the ISA Bus to Make the VG-PD6722 DMA-Capable**

Terminal counts are passed through to the card from the VG-PD6722 -VPP\_VALID pin when bit 6 of the **Misc Control 2** register is '1'. For a DMA write process, the last-cycle terminal count condition is indicated by -OE being active-low during a card DMA data read cycle. For a DMA read process, terminal count is indicated by -WE being active-low during the last card cycle.

### 13.4 Configuring the VG-PD6722 Registers for a DMA Transfer

Program the registers as follows to configure a VG-PD6722 socket interface for DMA transfer to/from a DMA-capable PC Card:

1. Select which pin on the PC Card interface will serve as the DMA request input.
2. Configure the socket interface as I/O-capable.
3. Prevent dual-interpretation of socket interface DMA handshake signals.
4. Set the DMA Enable bit.



### 13.4.1 Programming the DMA Request Pin from the Card

The VG-PD6722 allows selection of one from three PC Card interface inputs to be redefined as the DMA request input, and it also allows programming of the active level of the selected input. This is done by setting bits 7 and 6 of the **Extension Control 1** register to the desired values matching those of the DMA-capable PC Card to be used.

Once this selection of DMA request input is complete, the PC Card interface is configured at the signal level for DMA card interfacing.

The following table shows how the VG-PD6722 socket interface signals are redefined when a card is in DMA card interface mode:

Standard I/O Card Interface Signal Name	DMA-Capable Card Interface Signal Usage	When Signal Redefinition for DMA Interface is Effective
-IOIS16	-IOIS16 or may be selected as the active-low DMA request input	<b>Extension Control 1</b> register bits 7-6 = '10'
(BVD2/) -SPKR/-LED	-SPKR/-LED or may be selected as the active-low DMA request input	<b>Extension Control 1</b> register bits 7-6 = '11'
-INPACK	-INPACK or may be selected as the active-low DMA request input	<b>Extension Control 1</b> register bits 7-6 = '01'
-REG	-REG during standard cycles, active-high DACK during DMA read/write cycles	Only during actual card DMA read or write cycle
-OE	-OE during standard cycles, active-low -TC during DMA write cycles	During DMA write cycles (that is, when -REG is high and -IORD is low)
-WE	-WE during standard cycles, active-low -TC during DMA read cycles	During DMA read cycles (that is, when -REG is high and -IOWR is low)

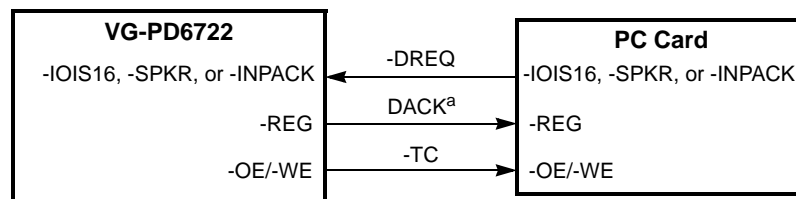

<sup>a</sup> A DMA cycle is the DMA acknowledge to the card.

**Figure 13-2. Card DMA Request and Acknowledge Handshake with Terminal Count**

Notice that the DMA acknowledge to the card as -REG high is only active during the actual DMA read or write card cycle. This means there is no mechanism to deassert DACK to the card: The card must understand that receiving the first DMA cycle is its DMA acknowledgment.



### **13.4.2 Configuring the Socket Interface for I/O**

For DMA support, bit 5 of the **Interrupt and General Control** register must be set to '1' to put the card interface in I/O Card Interface mode.

### **13.4.3 Preventing Dual Interpretation of DMA Handshake Signals**

If the WP/-IOIS16 pin is being used as the DMA request line, the following should be considered:

- 1) Bit 4 of the **Interface Status** register is now the level of the DMA request line from the card.
- 2) Bit 5 of the socket's two I/O Window Control registers should be set to '0'.

If a socket's BVD2/-SPKR pin is being used as the DMA request line, speaker or LED output from that socket is not available.

If -INPACK is selected as the DMA request input, then bit 7 of the **Misc Control 1** register should be set to '0' to disable use of this signal as input acknowledge control.

No other register bits require special settings to accommodate DMA support on a socket interface.

### **13.4.4 Turning On DMA System**

The DMA System bit (bit 6 of the **Misc Control 2** register) should be programmed to '1' to allow DMA operation and to redefine ISA bus interface pins for DMA support as in Figure 13-1.

## **13.5 The DMA Transfer Process**

As soon as the selected DMA request input from the card becomes active (low) and the FIFO empties, IRQ10 becomes active (high), signifying a DMA request to the system. The system then responds with an active (low) -DACK at IRQ9, which enables the VG-PD6722 to decode any ISA bus DMA transfers that may occur and perform the corresponding transfers at the card. Normal card I/O or memory reads or writes may be interspersed with DMA read and write cycles.

## **13.6 Terminal Count to Card at Conclusion of Transfer**

At the conclusion of each transfer process, systems send active (high) TC (terminal count) pulses to the -VPP\_VALID pin during the last DMA cycles to the VG-PD6722.

For a DMA write cycle, TC active is signaled at the socket interface as the -OE pin going low during DMA-type read cycles from the PC Card.

For a DMA read cycle, TC active is signaled as the -WE pin going low during DMA-type write cycles to the PC Card.





## 14. ELECTRICAL SPECIFICATIONS

### 14.1 Absolute Maximum Ratings

Ambient temperature under bias	0°C to 70°C
Storage temperature	-65°C to 150°C
Voltage on any pin (with respect to ground)	-0.5 volts to 0.5 volts greater than voltage of +5V pin, respective to ground
Operating power dissipation	500 mW
Suspend power dissipation	10 mW
Power supply voltage	7 volts
Injection current (latch up)	25 mA

**CAUTION:** Stresses above those listed may cause permanent damage to system components. These are stress ratings only; functional operation at these or any conditions above those indicated in the operational sections of this specification is not implied. Exposure to absolute maximum rating conditions for extended periods may affect system reliability.

### 14.2 DC Specifications

**Table 14-1. General DC Specifications**

Symbol	Parameter	MIN	MAX	Unit	Conditions
C <sub>IN</sub>	Input Capacitance		10.0	pF	
C <sub>OUT</sub>	Output Capacitance		10.0	pF	
I <sub>IL</sub>	Input Leakage	-10.0	10.0	μA	0 < V <sub>IN</sub> < respective V <sub>CC</sub> supply pin
I <sub>PU</sub>	Internal Pull-up Current	-30	-400	μA	



**Table 14-2. PC Card Bus Interface DC Specifications**

Symbol	Parameter	MIN	MAX	Unit	Conditions
SOCKET_VCC <sub>5V</sub>	Power Supply Voltage	4.5	5.5	V	Normal operation
SOCKET_VCC <sub>3V</sub>	Power Supply Voltage	3.0	3.6	V	
V <sub>IH</sub>	Input High Voltage	2.0		V	CORE_VDD = 3.0 V, <b>Misc Control 2</b> register, bit 3 is '0'
		2.0		V	CORE_VDD = 4.5 V, <b>Misc Control 2</b> register, bit 3 is '1'
V <sub>IL</sub>	Input Low Voltage		0.8	V	CORE_VDD = 3.6 V, <b>Misc Control 2</b> register, bit 3 is '0'
			0.8	V	CORE_VDD = 5.5 V, <b>Misc Control 2</b> register, bit 3 is '1'
V <sub>IHC</sub>	Input High Voltage CMOS	0.7 V <sub>DD</sub>		V	CORE_VDD = 4.5 V, <b>Misc Control 2</b> register, bit 3 is '0'
V <sub>ILC</sub>	Input Low Voltage CMOS		0.2 V <sub>DD</sub>	V	CORE_VDD = 5.5 V, <b>Misc Control 2</b> register, bit 3 is '0'
V <sub>OH</sub>	Output High Voltage	2.4		V	At rated I <sub>OH</sub> , respective SOCKET_VCC = 3.0 V
V <sub>OHC</sub>	Output High Voltage CMOS	SOCKET_VCC – 0.5		V	At rated I <sub>OHC</sub> , respective SOCKET_VCC = 3.0 V
V <sub>OL</sub>	Output Low Voltage		0.5	V	At rated I <sub>OL</sub>
I <sub>OH</sub>	Output High Current	–2		mA	Respective SOCKET_VCC = 3.0 V, V <sub>OH</sub> = 2.4V
I <sub>OHC</sub>	Output High Current CMOS	–1		mA	Respective SOCKET_VCC = 3.0 V, V <sub>OHC</sub> = SOCKET_VCC – 0.5 V
I <sub>OL</sub>	Output Low Current	2		mA	Respective SOCKET_VCC = 3.0 V, V <sub>OL</sub> = 0.5 V



**Table 14-3. ISA Bus Interface DC Specifications**

Symbol	Parameter	MIN	MAX	Unit	Conditions
ISA_VCC <sub>5V</sub>	Power Supply Voltage	4.5	5.5	V	Normal operation
ISA_VCC <sub>3V</sub>	Power Supply Voltage	3.0	3.6	V	Normal operation
V <sub>IH</sub> <sup>a</sup>	Input High Voltage	2.0		V	CORE_VDD = 3.0 V
V <sub>IL</sub> <sup>a</sup>	Input Low Voltage		0.8	V	CORE_VDD = 3.6 V
V <sub>IHC</sub> <sup>a</sup>	Input High Voltage CMOS	0.7 V <sub>DD</sub> <sup>b</sup>		V	CORE_VDD = 4.5 V
V <sub>ILC</sub> <sup>a</sup>	Input Low Voltage CMOS		0.2 V <sub>DD</sub> <sup>b</sup>	V	CORE_VDD = 5.5 V
V <sub>OH</sub>	Output High Voltage	2.4		V	At rated I <sub>OH</sub> , ISA_VCC = 3.0 V
V <sub>OHC</sub>	Output High Voltage CMOS	ISA_VCC - 0.5		V	At rated I <sub>OHC</sub> , ISA_VCC = 3.0 V
V <sub>OL</sub>	Output Low Voltage		0.5	V	At rated I <sub>OL</sub>
I <sub>OH</sub>	Output Current High, 2-mA-type driver	-2		mA	ISA_VCC = 3.0 V, V <sub>OH</sub> = 2.4 V
	Output Current High, 12-mA-type driver	-5		mA	
	Output Current High, 16-mA-type driver	-5		mA	
I <sub>OHC</sub>	Output Current High CMOS, 2-mA-type driver	-1		mA	ISA_VCC = 3.0 V, V <sub>OHC</sub> = ISA_VCC - 0.5 V
	Output Current High CMOS, 12-mA-type driver	-1		mA	
	Output Current High CMOS, 16-mA-type driver	-1		mA	
I <sub>OL</sub>	Output Current Low, 2-mA-type driver	2		mA	ISA_VCC = 3.0 V, V <sub>OL</sub> = 0.5 V
	Output Current Low, 12-mA-type driver	12		mA	
	Output Current Low, 16-mA-type driver	16		mA	

<sup>a</sup> When the CORE\_VDD voltage is 3.3 V, input thresholds are TTL compatible; when the CORE\_VDD voltage is 5 V, input thresholds are CMOS compatible.

<sup>b</sup> The value of the input threshold level is dependent on the voltage applied to V<sub>DD</sub> pins of the VG-PD67XX.



**Table 14-4. Power Control Interface (+5V Powered) DC Specifications**

Symbol	Parameter	MIN	MAX	Unit	Conditions
+5V	+5V Supply Voltage	Highest $V_{CC} - 0.3$	5.5	V	
$V_{IH}$	Input High Voltage	2.0		V	+5V pin voltage = 4.5 V
$V_{IL}$	Input Low Voltage		0.8	V	+5V pin voltage = 5.5 V
$V_{OH}$	Output High Voltage	2.4		V	+5V pin voltage = 4.5 V, $I_{OH} = -5$ mA
$V_{OHC}$	Output High Voltage CMOS	+5V volt- age - 0.5		V	+5V pin voltage = 4.5 V, $I_{OH} = -1$ mA
$V_{OL}$	Output Low Voltage		0.5	V	
$I_{OH}$	Output Current High, 16-mA-type driver	-5		mA	Respective +5V pin voltage = 4.5 V, $V_{OH} = 2.4$ V
$I_{OHC}$	Output Current High CMOS, 16-mA-type driver	-1		mA	Respective +5V pin voltage = 4.5 V, $V_{OHC} = +5V$ pin voltage - 0.5 V
$I_{OL}$	Output Current Low, 16-mA-type driver	16		mA	Respective +5V pin voltage = 4.5 V, $V_{OL} = 0.5$ V

**Table 14-5. Operating Current Specifications**

Symbol	Parameter	MIN	TYP	MAX	Unit	Conditions
$I_{cc\text{tot}(1)}$	Power Supply Current, operating	< 6	8	< 20	mA	CORE_VDD = 3.3 V; +5V, SOCKET_VCC, and ISA_VCC = 5.0 V; $P_{DISS} = < 85$ mW
$I_{cc\text{tot}(2)}$	Power Supply Current, Suspend <sup>a</sup>		< 150		$\mu$ A	CORE_VDD = 3.3 V; +5V, SOCKET_VCC, and ISA_VCC = 5.0 V; $P_{DISS} = < 2$ mW
$I_{cc\text{tot}(3)}$	Power Supply Current, Super Suspend, No Clocks <sup>a</sup>		< 20		$\mu$ A	CORE_VDD = 3.3 V; +5V, SOCKET_VCC, and ISA_VCC = 5.0 V; $P_{DISS} = < 1$ mW

<sup>a</sup> No cards in sockets; for VG-PD6722, bit 5 of the DMA Control register is '1'.



### 14.3 AC Timing Specifications

This section includes system timing requirements for the VG-PD67XX. Timings are provided in nanoseconds (ns), at TTL input levels, with the ambient temperature varying from 0°C to 70°C, and  $V_{CC}$  varying from 3.0 to 3.6 V or 4.5 to 5.5 V DC. The AT bus speed is 10 MHz unless otherwise noted. Note that an asterisk (\*) denotes an active-low signal for the ISA bus interface, and a dash (-) denotes an active-low signal for the PC Card socket interface.

Additionally, the following statements are true for all timing information:

- 1 All timings assume a load of 50 pF.
- 1 TTL signals are measured at TTL threshold; CMOS signals are measured at CMOS threshold.

**Table 14-6. List of AC Timing Specifications**

Title	Page Number
Table 14-7. ISA Bus Timing	84
Table 14-8. Reset Timing	86
Table 14-9. Pulse Mode Interrupt Timing	87
Table 14-10. General-Purpose Strobe Timing	88
Table 14-11. Input Clock Specification	89
Table 14-12. Memory Read/Write Timing (Word Access)	91
Table 14-13. Word I/O Read/Write Timing	92
Table 14-14. PC Card Read/Write Timing when System Is 8-Bit	94
Table 14-15. Normal Byte Read/Write Timing	95
Table 14-16. 16-Bit System to 8-Bit I/O Card: Odd Byte Timing	96
Table 14-17. DMA Read Cycle Timing (VG-PD6722 only)	97
Table 14-18. DMA Write Cycle Timing (VG-PD6722 only)	99
Table 14-19. DMA Request Timing (VG-PD6722 only)	101



14.3.1 ISA Bus Timing

Table 14-7. ISA Bus Timing

Symbol	Parameter	MIN	MAX	Unit
t <sub>1</sub>	MEMCS16* active delay from LA[23:17] valid		40	ns
t <sub>1a</sub>	LA[23:17] setup to ALE inactive	30		ns
t <sub>1b</sub>	LA[23:17] hold from ALE inactive	5		ns
t <sub>2</sub>	IOCS16* active delay from SA[15:0] <sup>1</sup>		40	ns
t <sub>2a</sub>	IOCS16* inactive delay from SA[15:0] <sup>1</sup>		40	ns
t <sub>3</sub>	SA[16:0], SBHE* setup to any Command active <sup>1, 2</sup> LA[23:17] latching by ALE to any Command active	30 90		ns ns
t <sub>4</sub>	Any Command active to IOCHRDY inactive (low) <sup>3</sup>		40	ns
t <sub>4a</sub>	IOCHRDY three-state from Command inactive <sup>4</sup>	5	30	
t <sub>5</sub>	MEMCS16* inactive delay from unlatched LA[23:17]		40	ns
t <sub>6a</sub>	IOW* or IOR* pulse width <sup>1</sup>	140		ns
t <sub>6b</sub>	MEMW* or MEMR* pulse width <sup>1</sup>	180		ns
t <sub>7</sub>	Any Command inactive to next Command active	100		ns
t <sub>8</sub>	Address or SBHE* hold from any Command inactive	0		ns
t <sub>9</sub>	Data valid from MEMW* active <sup>5</sup> Data valid from IOW* active		40 40	ns ns
t <sub>10</sub>	Data hold from MEMW* inactive Data hold from IOW* inactive	5 5		ns ns
t <sub>11</sub>	Data delay from IOR* active, for internal registers	0	130	ns
t <sub>12</sub>	Data delay from IOCHRDY active		15	ns
t <sub>13</sub>	Data hold from IOR* or MEMR* inactive	0	30	ns
t <sub>14</sub>	AEN inactive setup to valid IOR* or IOW* active	40		ns
t <sub>15</sub>	AEN hold from IOR* or IOW* inactive	5		ns
t <sub>16</sub>	REFRESH* inactive setup to valid MEMR* or MEMW* active	40		ns
t <sub>17</sub>	REFRESH* inactive hold from MEMR* or MEMW* active	0		ns
t <sub>18</sub>	MEMCS16* active delay from SA[16:12] valid		40	ns
t <sub>19</sub>	*ZWS delay from MEMW* active		30	ns
t <sub>20</sub>	*ZWS hold from MEMW* inactive		15	ns

<sup>1</sup> AEN must be inactive for t<sub>2</sub>, t<sub>3</sub>, and t<sub>6</sub> timing specifications to be applicable.  
<sup>2</sup> Command is defined as IOR\*, IOW\*, MEMR\*, or MEMW\*.  
<sup>3</sup> Except for valid card memory writes, which are zero wait state when internal write FIFO is not full.  
<sup>4</sup> If card is removed during a card access cycle, IOCHRDY is three-stated without waiting for end of Command.  
<sup>5</sup> Based on 25-MHz internal clock, produced either by an internal synthesizer and 14.318-MHz signal applied to CLK pin, or by supplying 25 MHz directly to CLK pin and bypassing the internal synthesizer.

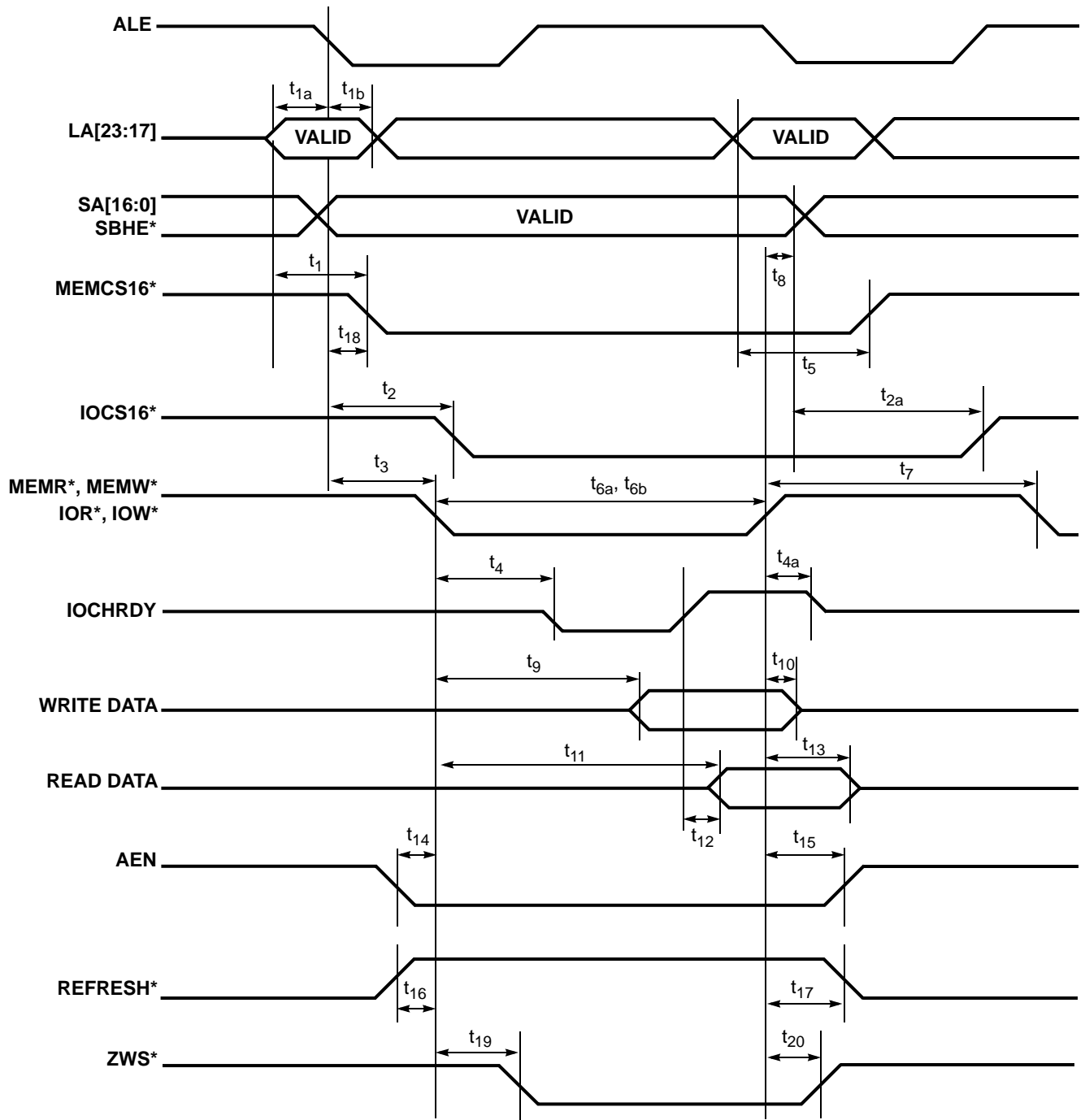

**Figure 14-1. Bus Timing — ISA Bus**



**14.3.2 Reset Timing**

**Table 14-8. Reset Timing**

Symbol	Parameter	MIN	MAX	Units
$t_1$	PWRGOOD generated reset pulse width	500		ns
$t_2$	Clock active before end of reset <sup>1</sup>	500		ns
$t_3$	End of PWRGOOD generated reset to first Command	500		ns

<sup>1</sup> Clock input must be active for a minimum of 500 ns before PWRGOOD goes active to allow sufficient internal clocks to initialize internal circuitry.

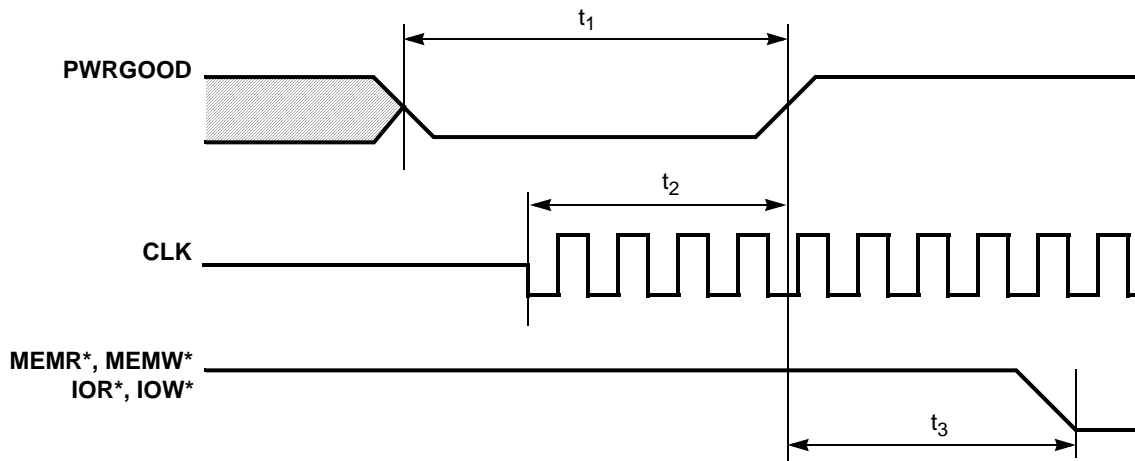

**Figure 14-2. Reset Timing**





**14.3.3 System Interrupt Timing**

**Table 14-9. Pulse Mode Interrupt Timing**

Symbol	Parameter	MIN	MAX
$t_1$	IRQ[XX] low or high	2 CLK – 10 ns	2 CLK + 10 ns

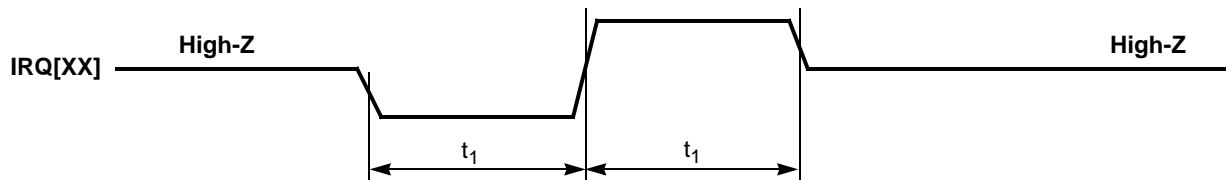

**High-Z = high impedance**

**NOTE:** Each time indicated is 2 clock periods of the CLK input to the VG-PD67XX, independent of setting of the Bypass Frequency Synthesizer bit.

**Figure 14-3. Pulse Mode Interrupt Timing**



**14.3.4 General-Purpose Strobe Timing (VG-PD6722 only)**

**Table 14-10. General-Purpose Strobe Timing**

Symbol	Parameter	MIN	MAX	Units
$t_1$	GPSTB delay after IOR* or IOW* active		40	ns
$t_2$	GPSTB delay after IOR* or IOW* inactive		40	ns

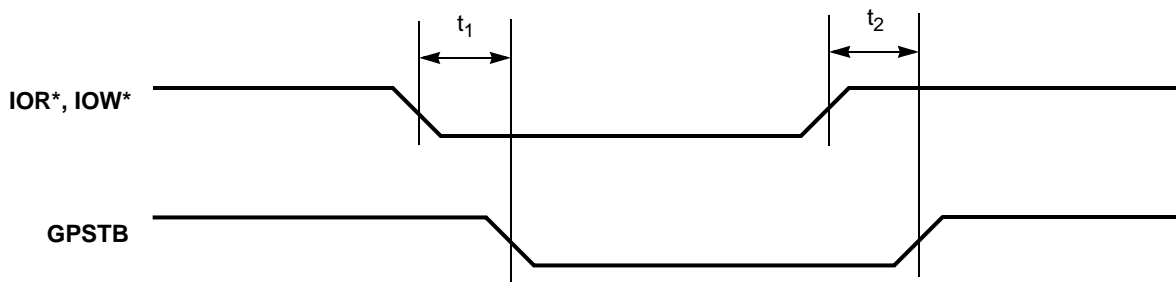

**Figure 14-4. General-Purpose Strobe Timing**



**14.3.5 Input Clock Specification**

**Table 14-11. Input Clock Specification**

Symbol	Parameter	MIN	MAX	Units	Conditions
$t_1$	CLK pin input rise time	1	7	ns	
$t_2$	CLK pin input fall time	1	7	ns	
$t_3$	CLK input low period	$0.4 T_{CLKP}$	$0.6 T_{CLKP}$	ns	
$t_4$	CLK input high period	$0.4 T_{CLKP}$	$0.6 T_{CLKP}$	ns	
$V_{center}$	Center voltage at which period specified	$0.5 V_{DD}$	$0.5 V_{DD}$	V	
$T_{CLKP}$	Input clock period, internal clock	$69.84 - 0.1\%$	$69.84 + 0.1\%$	ns	Normal synthesizer operation. Misc Control 2 register, bit 0 = '0'. CLK pin at 14.318 MHz.
$T_{CLKP}$	Input clock period, external clock	$40 - 0.1\%$	$40 + 0.1\%$	ns	Synthesizer bypassed. Misc Control 2 register, bit 0 = '1'. CLK pin at 25 MHz.
$V_{IHmin}$	CLK input high voltage	2.0		V	CORE_VDD = 3.0 V
$V_{ILmax}$	CLK input low voltage		0.8	V	CORE_VDD = 3.6 V
$V_{IHCmin}$	CLK input high voltage	$0.7 V_{DD}$		V	CORE_VDD = 4.5 V
$V_{ILCmax}$	CLK input low voltage		$0.2 V_{DD}$	V	CORE_VDD = 5.5 V

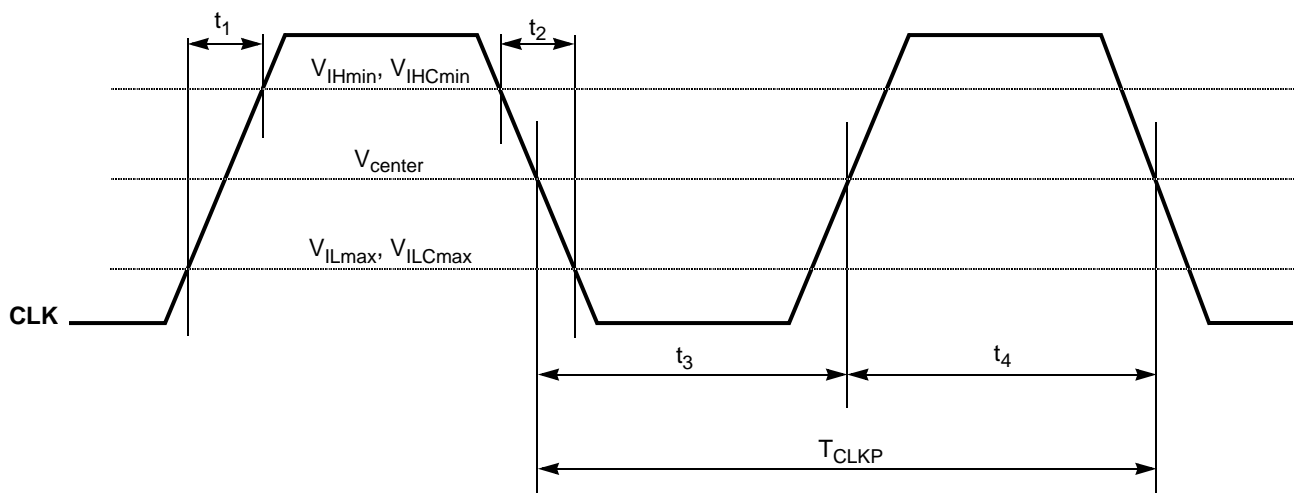

**Figure 14-5. Input Clock Specification**



### 14.3.6 PC Card Bus Timing Calculations

Calculations for minimum PC Card cycle Setup, Command, and Recovery timings are made by first calculating factors derived from the applicable timer set's timing registers and then by applying the factor to an equation relating it to the internal clock period.

The PC Card cycle timing factors, in terms of the number of internal clocks, are calculated as follows:

$$S = (N_{pres} \times N_{val}) + 1 \quad \text{Equation 14-1}$$

$$C = (N_{pres} \times N_{val}) + 1 \quad \text{Equation 14-2}$$

$$R = (N_{pres} \times N_{val}) + 1 \quad \text{Equation 14-3}$$

$N_{pres}$  and  $N_{val}$  are the specific selected prescaler and multiplier value from the timer set's Setup, Command, and Recovery Timing registers (see Chapter 9 for a description of these registers).

From this, a PC Card cycle's Setup, Command, and Recovery time for the selected timer set are calculated as follows:

$$\text{Setup time} = (S \times T_{cp}) \pm 10 \text{ ns} \quad \text{Equation 14-4}$$

$$\text{Command time} = (C \times T_{cp}) \pm 10 \text{ ns} \quad \text{Equation 14-5}$$

$$\text{Recovery time} = (R \times T_{cp}) \pm 10 \text{ ns} \quad \text{Equation 14-6}$$

When the internal synthesizer is used, the calculation of the internal clock period  $T_{cp}$  is:

$$T_{cp} = T_{CLKP} \times 4/7 \quad \text{Equation 14-7}$$

where  $T_{CLKP}$  is the period of the clock supplied to the CLK input pin. An input frequency of 14.318 MHz at the CLK input pin results in an internal clock period of  $T_{cp} = 40 \text{ ns}$ .

When the internal synthesizer is bypassed,  $T_{cp} = T_{CLKP}$ . An input frequency of 25 MHz in this circumstance would also result in an internal clock period of  $T_{cp} = 40 \text{ ns}$ .

The timing diagrams that follow were derived for a VG-PD67XX using the internal synthesizer and a 14.318-MHz CLK pin input. The internal clock frequency of the VG-PD67XX is 7/4 of this incoming signal ( $T_{cp} = 40 \text{ ns}$ ). The examples are for the default values of the Timing registers for Timer Set 0, as follows:

Timing Register Name (Timer Set 0)	Index	Value (Default)	Resultant $N_{pres}$	Resultant $N_{val}$
Setup Timing 0	3Ah	01h	1	1
Command Timing 0	3Bh	06h	1	6
Recovery Timing 0	3Ch	03h	1	3

Thus the minimum times for the default values are as follows:

$$\text{Default minimum Setup time} = (S \times T_{cp}) - 10 \text{ ns} = \{2 \times 40 \text{ ns}\} - 10 \text{ ns} = 70 \text{ ns} \quad \text{Equation 14-8}$$

$$\text{Default minimum Command time} = (C \times T_{cp}) - 10 \text{ ns} = \{7 \times 40 \text{ ns}\} - 10 \text{ ns} = 270 \text{ ns} \quad \text{Equation 14-9}$$

$$\text{Default minimum Recovery time} = (R \times T_{cp}) - 10 \text{ ns} = \{4 \times 40 \text{ ns}\} - 10 \text{ ns} = 150 \text{ ns} \quad \text{Equation 14-10}$$



### 14.3.7 PC Card Socket Timing

Table 14-12. Memory Read/Write Timing (Word Access)

Symbol	Parameter	MIN	MAX	Units
$t_1$	-CE[2:1], -REG, Address, and Write Data setup to Command active <sup>1</sup>	$(S \times T_{cp}) - 10$		ns
$t_2$	Command pulse width <sup>2</sup>	$(C \times T_{cp}) - 10$		ns
$t_3$	Address hold and Write Data valid from Command inactive <sup>3</sup>	$(R \times T_{cp}) - 10$		ns
$t_4$	-WAIT active from Command active <sup>4</sup>		$(C - 2)T_{cp} - 10$	ns
$t_5$	Command hold from -WAIT inactive	$(2 T_{cp}) + 10$		ns
$t_6$	Data valid from -WAIT inactive		$T_{cp} + 10$	ns
$t_7$	Data setup before -OE inactive	$(2 T_{cp}) + 10$		ns
$t_8$	Data hold after -OE inactive	0		ns

<sup>1</sup> The Setup time is determined by the value programmed into the **Setup Timing** register, index 3Ah/3Dh. Using the Timer Set 0 default value of 01h, the setup time would be 70 ns.  $S = (N_{pres} \times N_{val} + 1)$ , see page 90.

<sup>2</sup> The Command time is determined by the value programmed into the **Command Timing** register, index 3Bh/3Eh. Using the Timer Set 0 default value of 06h, the Command time would be 270 ns.  $C = (N_{pres} \times N_{val} + 1)$ , see page 90.

<sup>3</sup> The Recovery time is determined by the value programmed into the **Recovery Timing** register, index 3Ch/3Fh. Using the Timer Set 0 default value of 03h, the hold (Recovery) time would be 150 ns.  $R = (N_{pres} \times N_{val} + 1)$ , see page 90.

<sup>4</sup> For typical active timing programmed at 280 ns, maximum -WAIT timing is 190 ns after Command active.

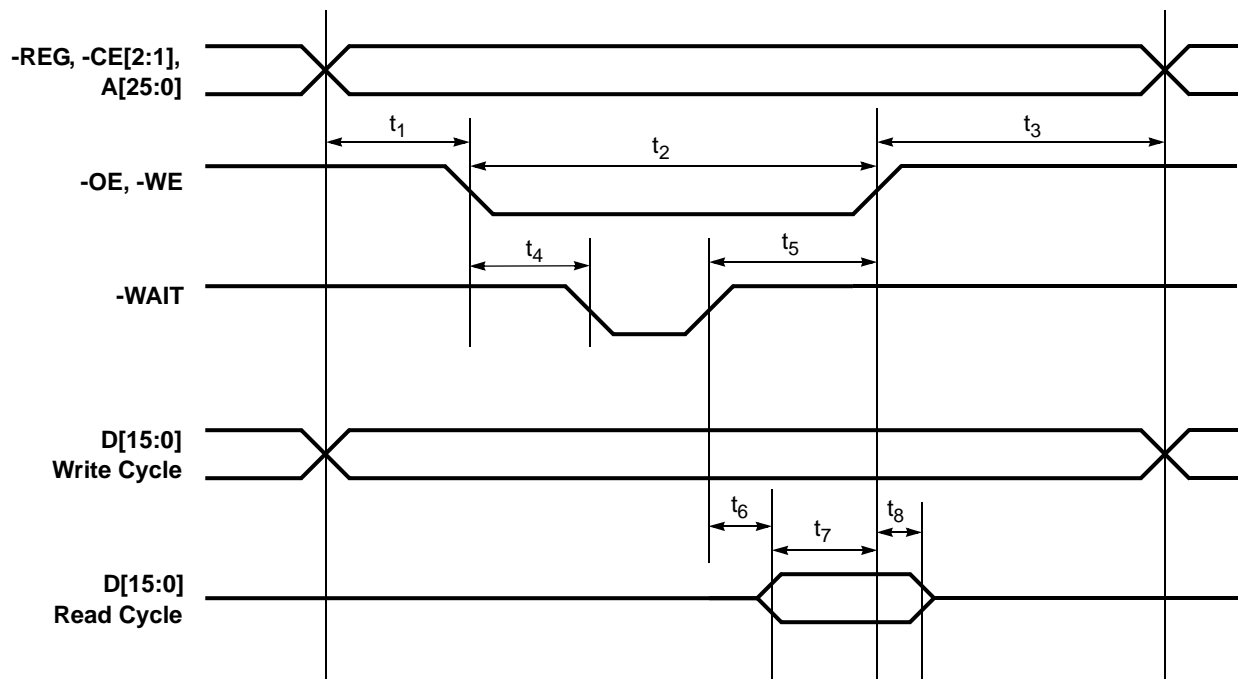

Figure 14-6. Memory Read/Write Timing



**Table 14-13. Word I/O Read/Write Timing**

Symbol	Parameter	MIN	MAX	Units
t <sub>1</sub>	-REG or Address setup to Command active <sup>1</sup>	(S × Tcp) – 10		ns
t <sub>2</sub>	Command pulse width <sup>2</sup>	(C × Tcp) – 10		ns
t <sub>3</sub>	Address hold and Write Data valid from Command inactive <sup>3</sup>	(R × Tcp) – 10		ns
t <sub>4</sub>	-WAIT active from Command active <sup>4</sup>		(C – 2)Tcp – 10	ns
t <sub>5</sub>	Command hold from -WAIT inactive	(2 Tcp) + 10		ns
t <sub>ref</sub>	Card -IOIS16 delay from valid Address (PC Card specification)		35	ns
t <sub>6</sub>	-IOIS16 setup time before Command end	(3 Tcp) + 10		ns
t <sub>7</sub>	-CE2 delay from -IOIS16 active <sup>5</sup>	Tcp – 10		ns
t <sub>6</sub>	Data valid from -WAIT inactive		Tcp + 10	ns
t <sub>9</sub>	Data setup before -IORD inactive	(2 Tcp) + 10		ns
t <sub>10</sub>	Data hold after -IORD inactive	0		ns

<sup>1</sup> The Setup time is determined by the value programmed into the **Setup Timing** register, index 3Ah/3Dh. Using the Timer Set 0 default value of 01h, the setup time would be 70 ns.  $S = (N_{pres} \times N_{val} + 1)$ , see page 90.

<sup>2</sup> The Command time is determined by the value programmed into the **Command Timing** register, index 3Bh/3Eh. Using the Timer Set 0 default value of 06h, the Command time would be 270 ns.  $C = (N_{pres} \times N_{val} + 1)$ , see page 90.

<sup>3</sup> The Recovery time is determined by the value programmed into the **Recovery Timing** register, index 3Ch/3Fh. Using the Timer Set 0 default value of 03h, the hold (Recovery) time would be 150 ns.  $R = (N_{pres} \times N_{val} + 1)$ , see page 90.

<sup>4</sup> For typical active timing programmed at 280 ns, maximum -WAIT timing is 190 ns after Command active.

<sup>5</sup> -IOIS16 must go low within 3Tcp + 10 ns of the cycle beginning or -IOIS16 will be ignored and -CE will not be activated.

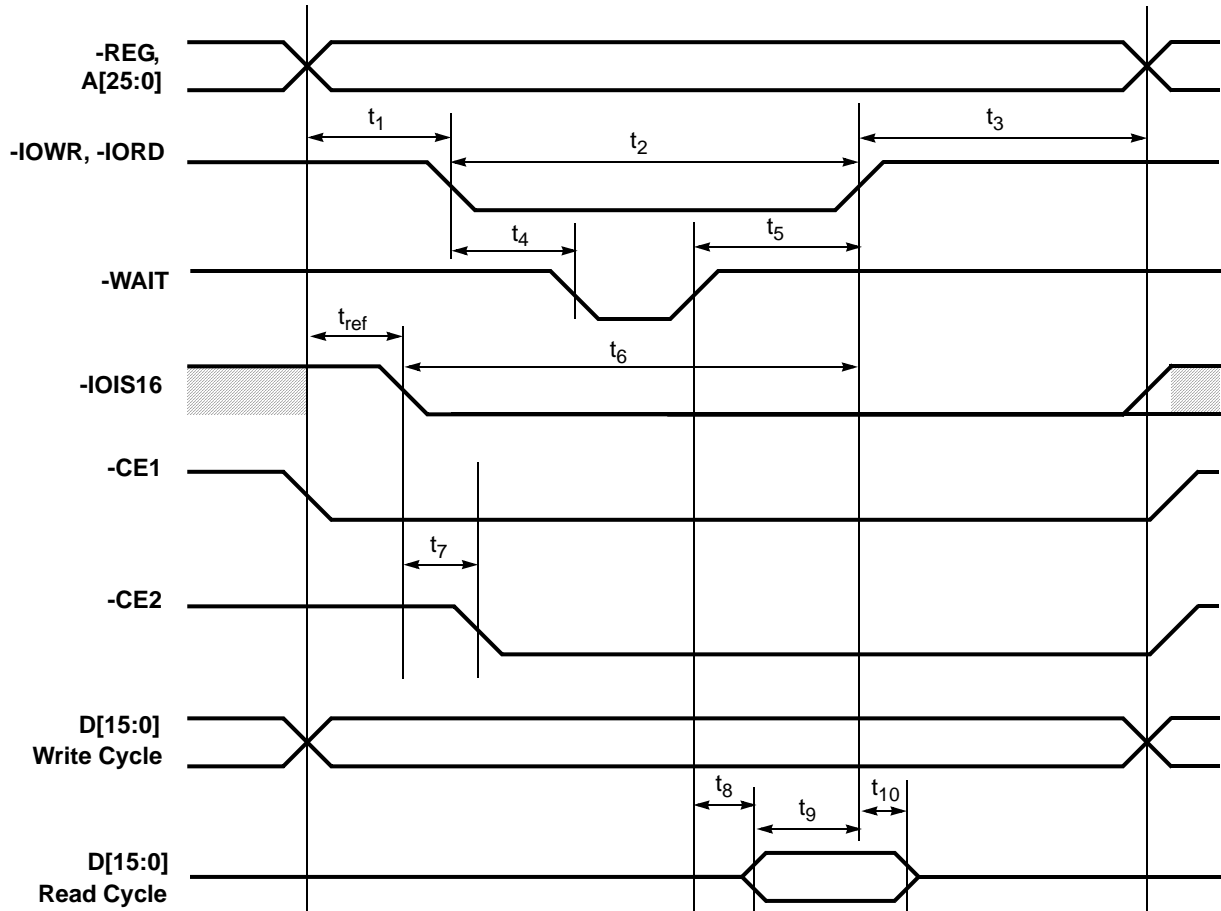

**Figure 14-7. Word I/O Read/Write Timing**



Table 14-14. PC Card Read/Write Timing when System Is 8-Bit

Symbol	Parameter	MIN	MAX	Units
$t_1$	-REG or Address setup to Command active <sup>1</sup>	$(S \times T_{cp}) - 10$		ns
$t_2$	Command pulse width <sup>2</sup>	$(C \times T_{cp}) - 10$		ns
$t_3$	Address hold from Command inactive <sup>3</sup>	$(R \times T_{cp}) - 10$		ns
$t_4$	Data setup before Command inactive	$(2 T_{cp}) + 10$		ns
$t_5$	Data hold after command inactive	0		ns

<sup>1</sup> The Setup time is determined by the value programmed into the **Setup Timing** register, index 3Ah/3Dh. Using the Timer Set 0 default value of 01h, the setup time would be 70 ns.  $S = (N_{pres} \times N_{val} + 1)$ , see page 90.

<sup>2</sup> The Command time is determined by the value programmed into the **Command Timing** register, index 3Bh/3Eh. Using the Timer Set 0 default value of 06h, the Command time would be 270 ns.  $C = (N_{pres} \times N_{val} + 1)$ , see page 90.

<sup>3</sup> The Recovery time is determined by the value programmed into the **Recovery Timing** register, index 3Ch/3Fh. Using the Timer Set 0 default value of 03h, the hold (Recovery) time would be 150 ns.  $R = (N_{pres} \times N_{val} + 1)$ , see page 90.

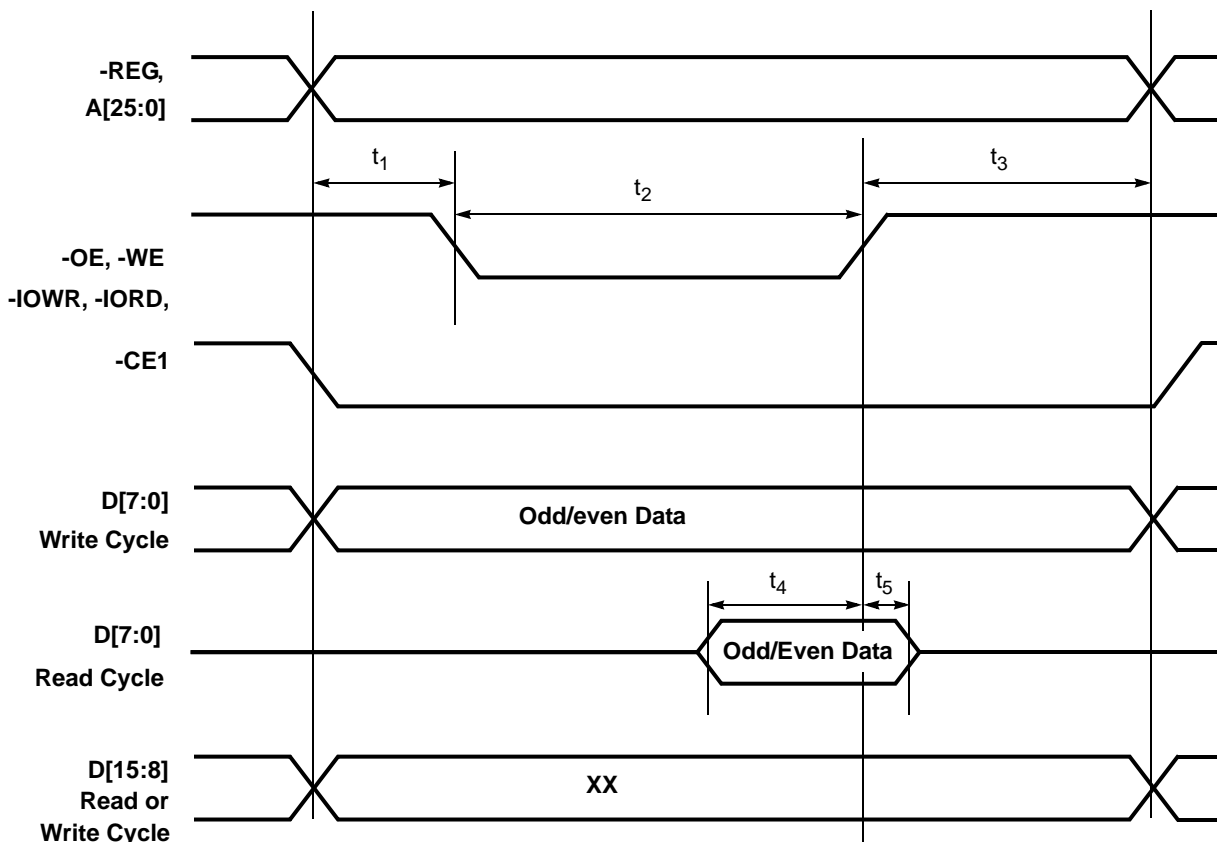

Figure 14-8. PC Card Read/Write Timing When System Is 8-Bit (SBHE Tied High)

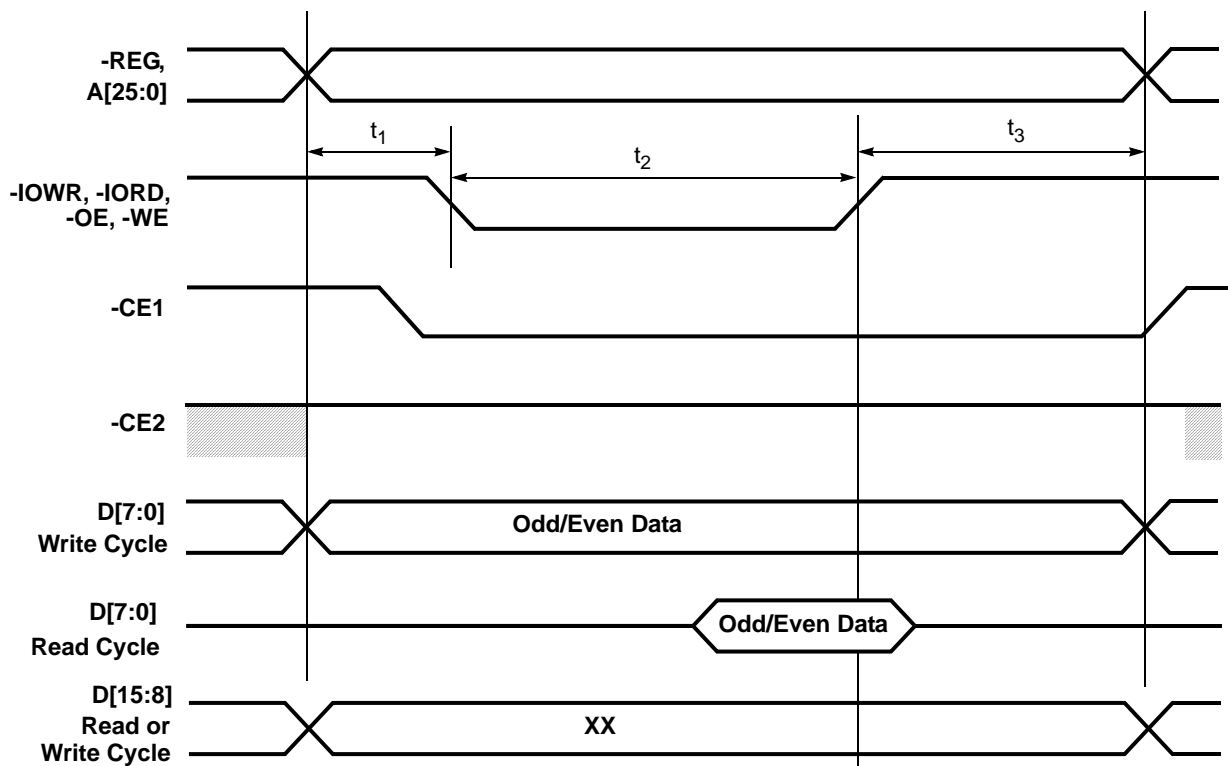



**Table 14-15. Normal Byte Read/Write Timing**

Symbol	Parameter	MIN	MAX	Units
$t_1$	Address setup to Command active <sup>1</sup>	$(S \times T_{cp}) - 10$		ns
$t_2$	Command pulse width <sup>2</sup>	$(C \times T_{cp}) - 10$		ns
$t_3$	Address hold from Command inactive <sup>3</sup>	$(R \times T_{cp}) - 10$		ns

<sup>1</sup> The Setup time is determined by the value programmed into the **Setup Timing** register, index 3Ah/3Dh. Using the Timer Set 0 default value of 01h, the setup time would be 70 ns.  $S = (N_{pres} \times N_{val} + 1)$ , see page 90.  
<sup>2</sup> The Command time is determined by the value programmed into the **Command Timing** register, index 3Bh/3Eh. Using the Timer Set 0 default value of 06h, the Command time would be 270 ns.  $C = (N_{pres} \times N_{val} + 1)$ , see page 90.  
<sup>3</sup> The Recovery time is determined by the value programmed into the **Recovery Timing** register, index 3Ch/3Fh. Using the Timer Set 0 default value of 03h, the hold (Recovery) time would be 150 ns.  $R = (N_{pres} \times N_{val} + 1)$ , see page 90.



**NOTE:** Figure 14-9 applies to all other byte accesses, including odd I/O cycles where -IOIS16 is low.

**Figure 14-9. Normal Byte Read/Write Timing**



Table 14-16. 16-Bit System to 8-Bit I/O Card: Odd Byte Timing

Symbol	Parameter	MIN	MAX	Units
$t_1$	Address change to -IOIS16 inactive <sup>4</sup>		$(3T_{cp}) + 10$	ns
$t_2$	-IOIS16 inactive to -CE2 inactive		20	ns
$t_3$	-IOIS16 inactive to -CE1 active		20	ns
$t_4$	Address setup to Command active <sup>1</sup>	$(S \times T_{cp}) - 10$		ns
$t_5$	Command pulse width <sup>2</sup>	$(C \times T_{cp}) - 10$		ns
$t_6$	Address hold from Command inactive <sup>3</sup>	$(R \times T_{cp}) - 10$		ns

<sup>1</sup> The Setup time is determined by the value programmed into the **Setup Timing** register, index 3Ah/3Dh. Using the Timer Set 0 default value of 01h, the setup time would be 70 ns.  $S = (N_{pres} \times N_{val} + 1)$ , see page 90.

<sup>2</sup> The Command time is determined by the value programmed into the **Command Timing** register, index 3Bh/3Eh. Using the Timer Set 0 default value of 06h, the Command time would be 270 ns.  $C = (N_{pres} \times N_{val} + 1)$ , see page 90.

<sup>3</sup> The Recovery time is determined by the value programmed into the **Recovery Timing** register, index 3Ch/3Fh. Using the Timer Set 0 default value of 03h, the hold (Recovery) time would be 150 ns.  $R = (N_{pres} \times N_{val} + 1)$ , see page 90.

<sup>4</sup> -IOIS16 level from card should be valid before -IOWR/-IORC goes active. For a typical setup time of 70 ns, a PC Card meeting the PCMCIA specification for -IOIS16 from A[25:0] change will meet this condition.

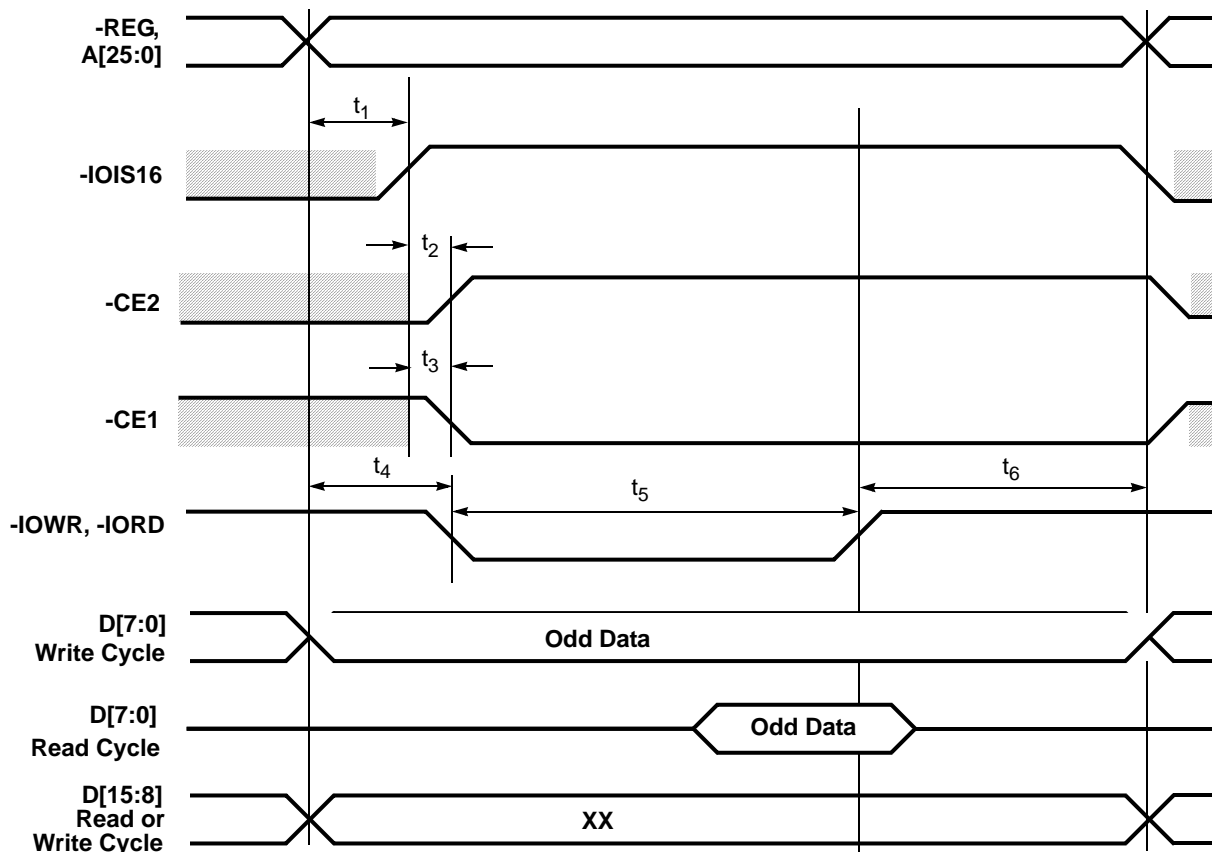

Figure 14-10. 16-Bit System to 8-Bit I/O Card: Odd Byte Timing



**Table 14-17. DMA Read Cycle Timing (VG-PD6722 only)**

Symbol	Parameter	MIN	MAX	Units
t <sub>1</sub>	DRQ (IRQ10) and DACK* (IRQ9) active to DMA cycle begin	40		ns
t <sub>2</sub>	-CE[2:1], -REG, -IORD, -OE, and Write Data setup to -IOWR active <sup>1</sup>	(S × T <sub>cp</sub> ) – 10		ns
t <sub>3</sub>	Command: -IOWR pulse width <sup>2</sup>	(C × T <sub>cp</sub> ) – 10		ns
t <sub>4</sub>	Recovery: -IOWR inactive to end of cycle <sup>3</sup>	(R × T <sub>cp</sub> ) – 10		ns
t <sub>5</sub>	-WAIT active from -IOWR active		(C – 2)T <sub>cp</sub> – 10	ns
t <sub>6</sub>	-WAIT inactive to -IOWR inactive	2 T <sub>cp</sub>		ns
t <sub>7</sub>	System TC (-VPP_VALID high) to -IOWR	–40		ns
t <sub>8</sub>	-IOWR to begin of card TC (-WE) <sup>4</sup>	25	50	ns
t <sub>9</sub>	End of card TC (-WE) to -IOWR inactive <sup>4</sup>	25	50	ns

<sup>1</sup> The Setup time is determined by the value programmed into the **Setup Timing** register, index 3Ah/3Dh. Using the Timer Set 0 default value of 01h, the setup time would be 70 ns. S = (N<sub>pres</sub> × N<sub>val</sub> + 1), see page 90.

<sup>2</sup> The Command time is determined by the value programmed into the **Command Timing** register, index 3Bh/3Eh. Using the Timer Set 0 default value of 06h, the Command time would be 270 ns. C = (N<sub>pres</sub> × N<sub>val</sub> + 1), see page 90.

<sup>3</sup> The Recovery time is determined by the value programmed into the **Recovery Timing** register, index 3Ch/3Fh. Using the Timer Set 0 default value of 03h, the hold (Recovery) time would be 150 ns. R = (N<sub>pres</sub> × N<sub>val</sub> + 1), see page 90.

<sup>4</sup> Based on an internal clock period of 40 ns (25 MHz).

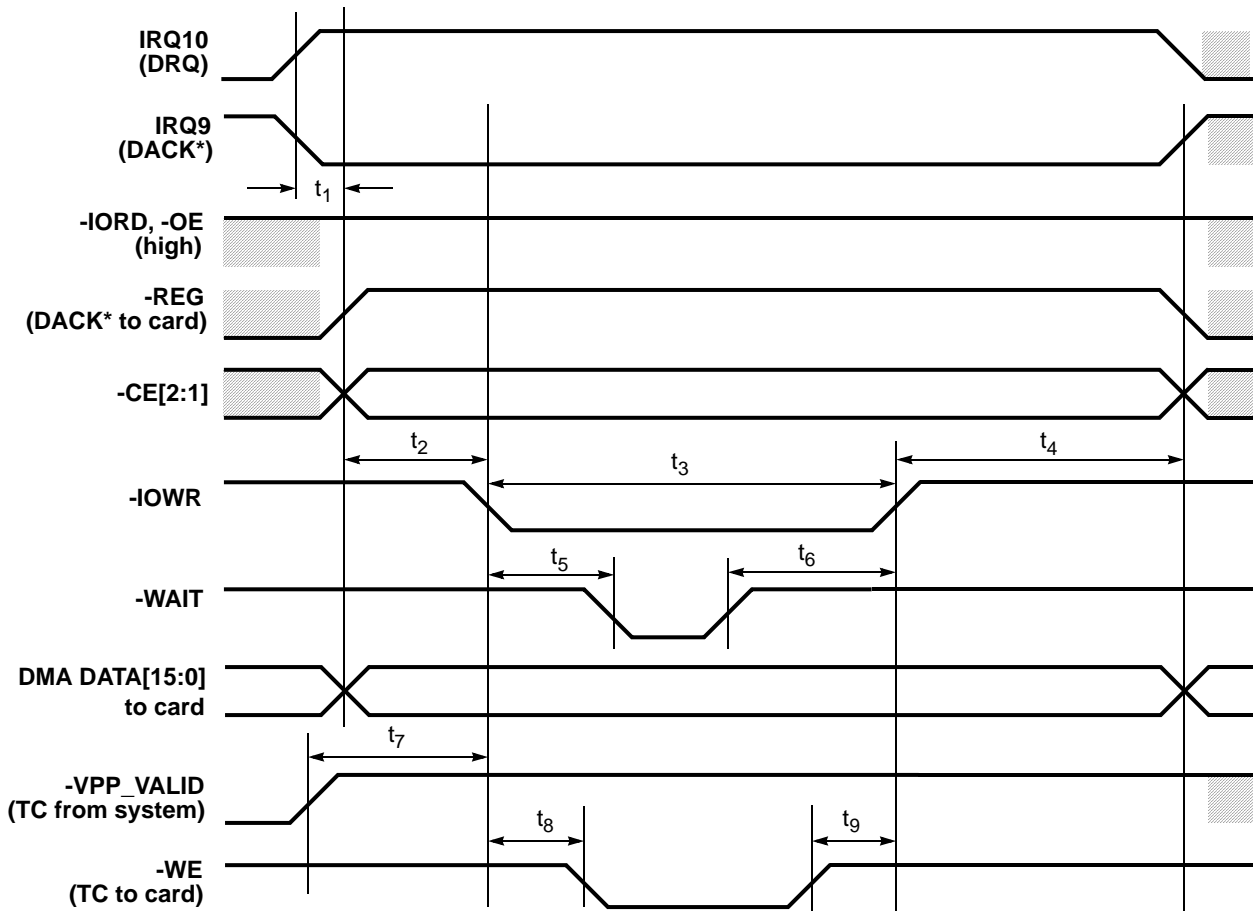

**Figure 14-11. DMA Read Cycle Timing**



**Table 14-18. DMA Write Cycle Timing (VG-PD6722 only)**

Symbol	Parameter	MIN	MAX	Units
t <sub>1</sub>	DRQ (IRQ10) and DACK* (IRQ9) active to DMA cycle begin	40		ns
t <sub>2</sub>	-CE[2:1], -REG, -IOWR, -WE, and Write Data setup to -IORD active <sup>1</sup>	(S × T <sub>cp</sub> ) – 10		ns
t <sub>3</sub>	Command: -IORD pulse width <sup>2</sup>	(C × T <sub>cp</sub> ) – 10		ns
t <sub>4</sub>	Recovery: -IORD inactive to end of cycle <sup>3</sup>	(R × T <sub>cp</sub> ) – 10		ns
t <sub>5</sub>	-WAIT active from -IORD active		(C – 2)T <sub>cp</sub> – 10	ns
t <sub>6</sub>	-WAIT inactive to -IORD inactive	2 T <sub>cp</sub>		ns
t <sub>7</sub>	System TC (-VPP_VALID high) to -IORD	–40		ns
t <sub>8</sub>	-IORD to begin of card TC (-OE) <sup>4</sup>	25	50	ns
t <sub>9</sub>	End of card TC (-OE) to -IORD inactive <sup>4</sup>	25	50	ns
t <sub>10</sub>	Data valid from -WAIT inactive	T <sub>cp</sub> + 10		ns
t <sub>11</sub>	Data setup before -OE inactive	(2 T <sub>cp</sub> ) + 10		ns
t <sub>12</sub>	Data hold after -OE inactive	0		ns

<sup>1</sup> The Setup time is determined by the value programmed into the **Setup Timing** register, index 3Ah/3Dh. Using the Timer Set 0 default value of 01h, the setup time would be 70 ns.  $S = (N_{pres} \times N_{val} + 1)$ , see page 90.

<sup>2</sup> The Command time is determined by the value programmed into the **Command Timing** register, index 3Bh/3Eh. Using the Timer Set 0 default value of 06h, the Command time would be 270 ns.  $C = (N_{pres} \times N_{val} + 1)$ , see page 90.

<sup>3</sup> The Recovery time is determined by the value programmed into the **Recovery Timing** register, index 3Ch/3Fh. Using the Timer Set 0 default value of 03h, the hold (Recovery) time would be 150 ns.  $R = (N_{pres} \times N_{val} + 1)$ , see page 90.

<sup>4</sup> Based on an internal clock period of 40 ns (25 MHz).

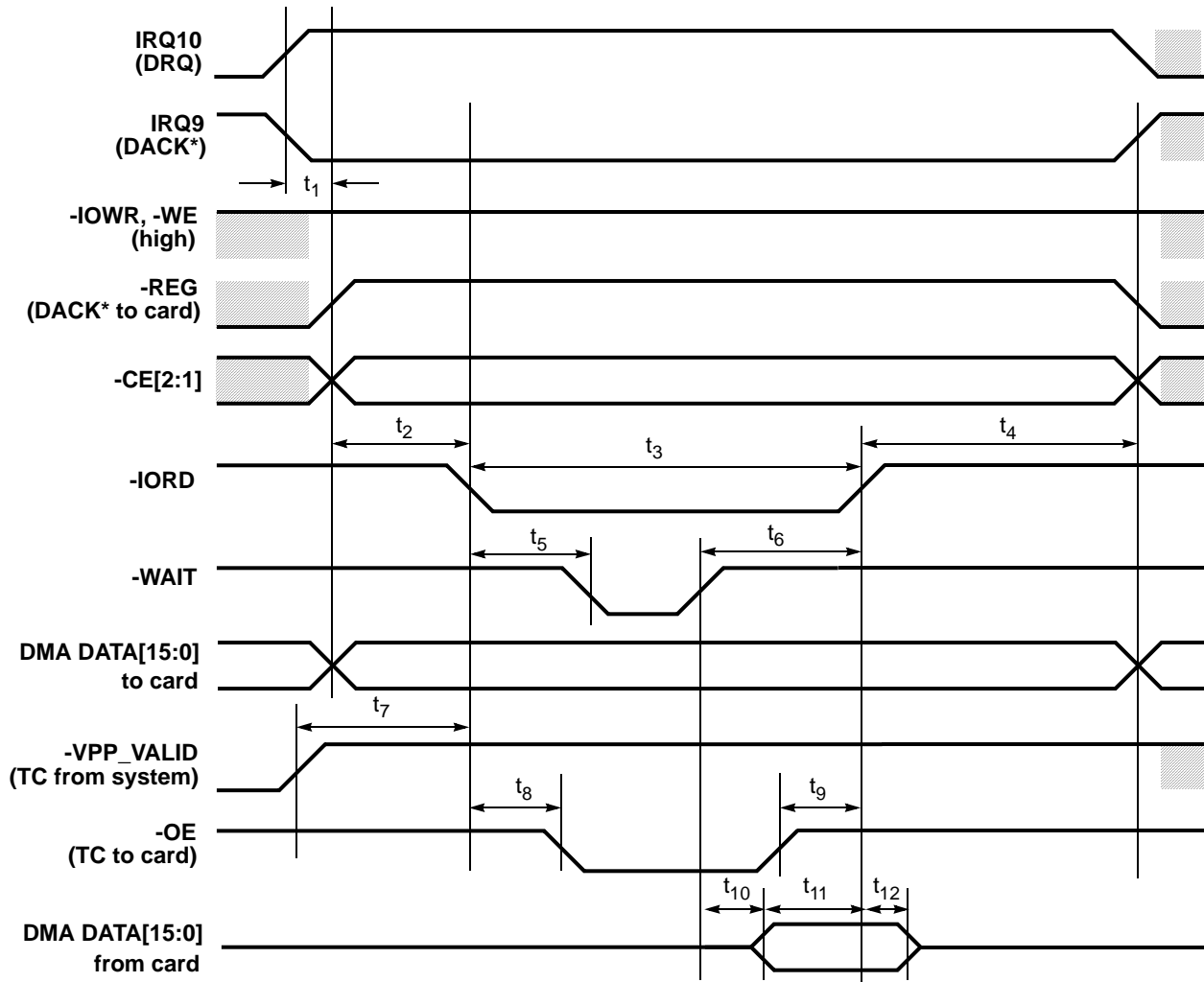
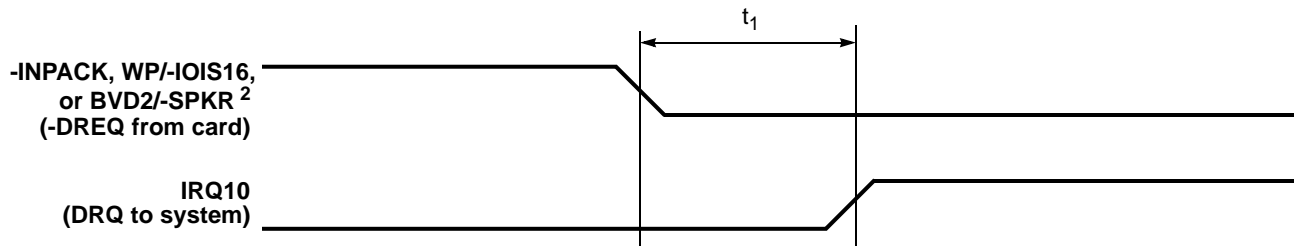

Figure 14-12. DMA Write Cycle Timing



**Table 14-19. DMA Request Timing (VG-PD6722 only)**

Symbol	Parameter	MIN	MAX	Units
$t_1$	DMA request from socket interface to system <sup>1</sup>	40		ns
<sup>1</sup> After FIFO empty, DMA requests held off from being presented to the system until all write data to a card has been emptied from the socket interface FIFO.				



<sup>2</sup> **DMA Control** register bits 7 and 6 define which of these three signals serve as the active-low DMA request from the card.

**Figure 14-13. DMA Request Timing**



## 15. PACKAGE SPECIFICATIONS

### 15.1 144-Pin VQFP Package

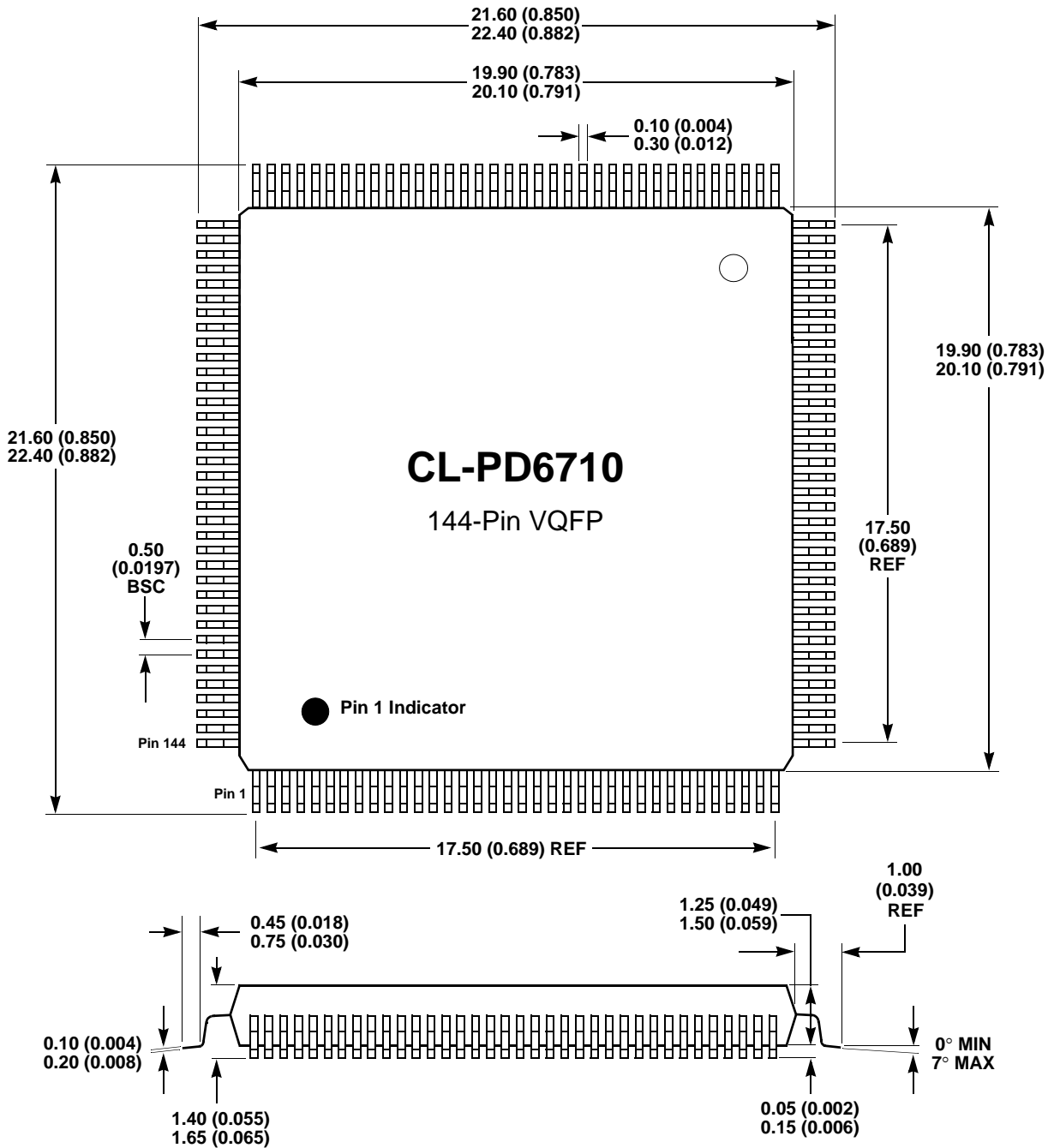

#### NOTES:

- 1) Dimensions are in millimeters (inches), and controlling dimension is millimeter.
- 2) Before beginning any new design with this device, please contact Amphus Corp. for the latest package information.



**15.2 208-Pin PQFP Package**

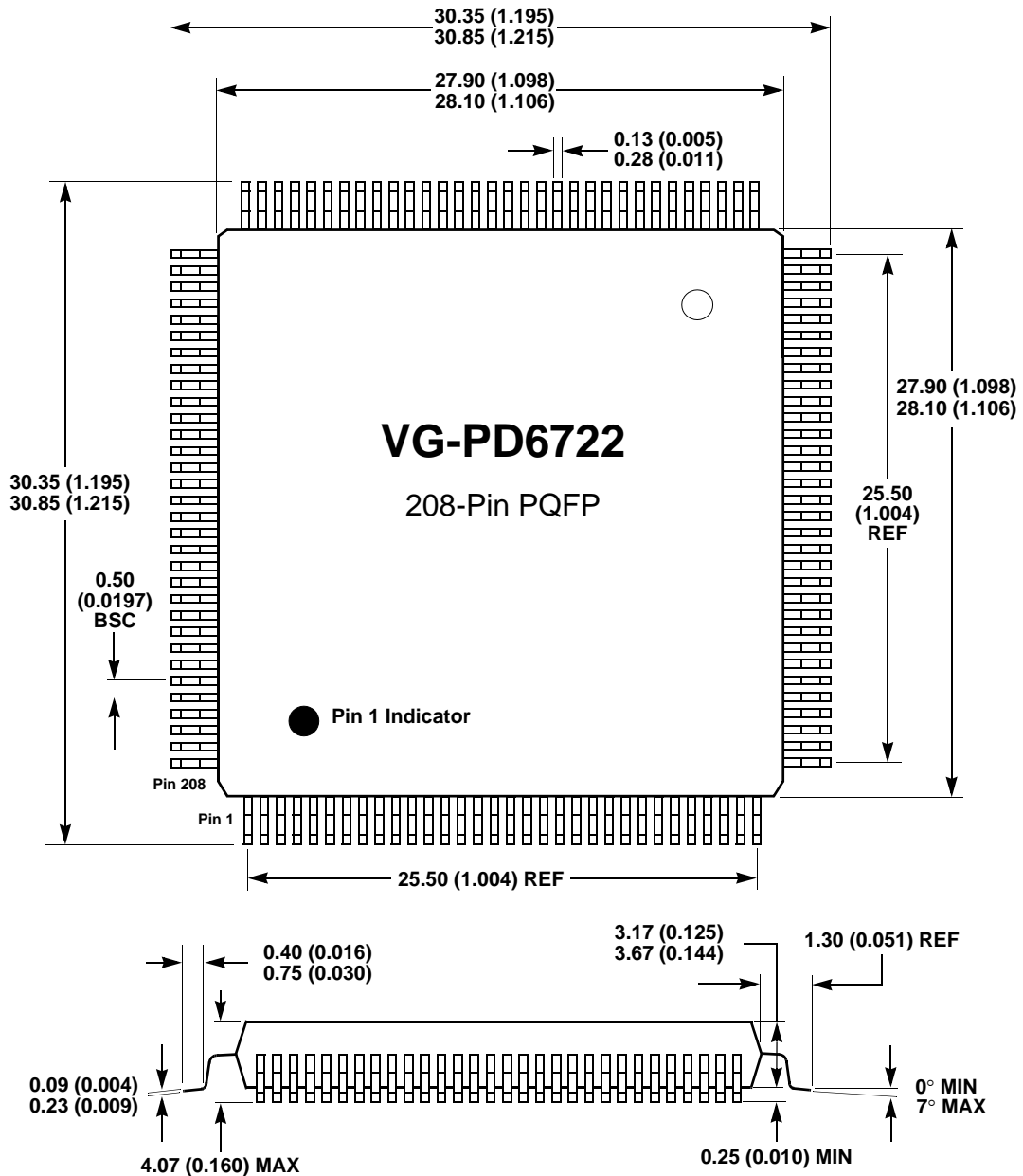

**NOTES:**

- 1) Dimensions are in millimeters (inches), and controlling dimension is inches.
- 2) Drawing above does not reflect exact package pin count.
- 3) Before beginning any new design with this device, please contact Amphus Corp. for the latest package information.



15.3 208-Pin VQFP Package

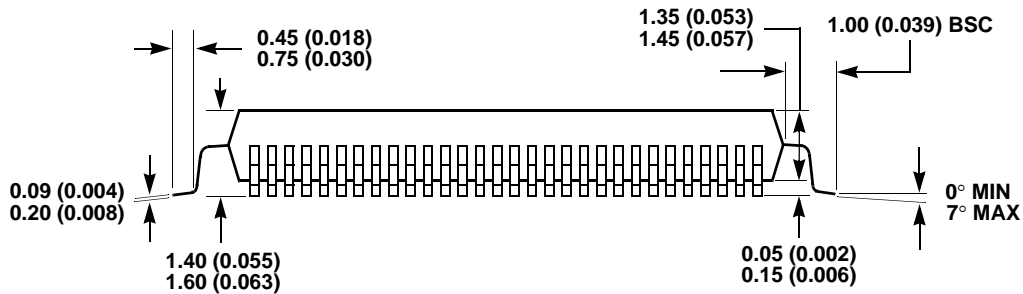
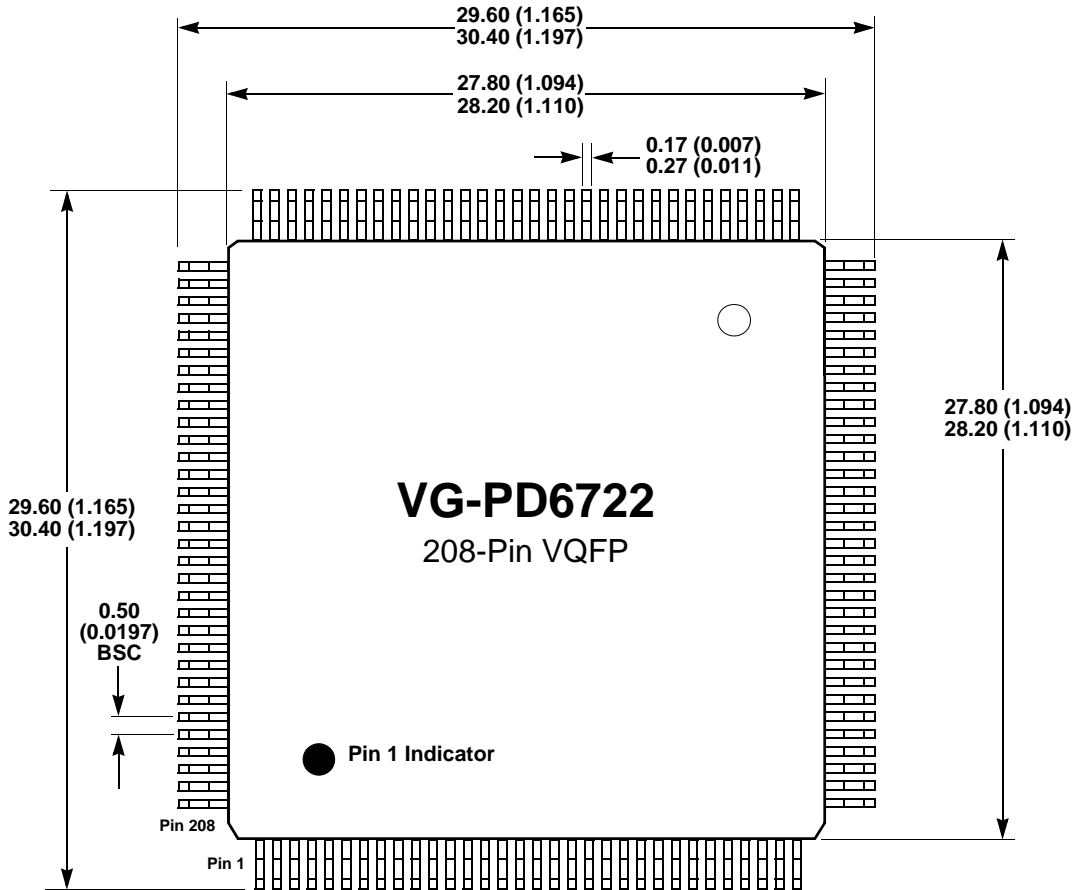

NOTES:

- 1) Dimensions are in millimeters (inches), and controlling dimension is inches.
- 2) Drawing above does not reflect exact package pin count.
- 3) Before beginning any new design with this device, please contact Amphus Corp. for the latest package information.



## 16. ORDERING INFORMATION EXAMPLE

The order number for the part is:

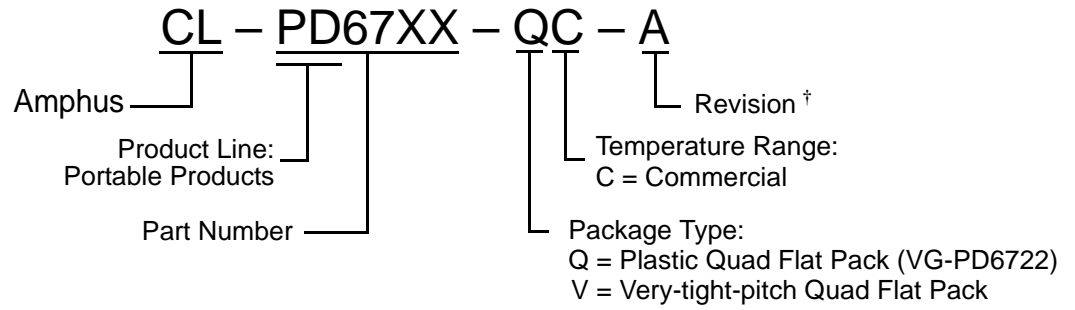

† Contact Amphus for up-to-date information on revisions.



## Appendix A

### Register Summary Tables

#### A.1 Operation Registers

<i>Register Name: Index</i>				<i>Register Per: chip</i>			
<i>Index: n/a</i>				<i>Register Compatibility Type: 365</i>			
<i>Bit 7</i>	<i>Bit 6</i>	<i>Bit 5</i>	<i>Bit 4</i>	<i>Bit 3</i>	<i>Bit 2</i>	<i>Bit 1</i>	<i>Bit 0</i>
Device Index	Socket Index	Register Index					
RW:0	RW:0	RW:000000					

<i>Register Name: Data</i>				<i>Register Per: chip</i>			
<i>Index: n/a</i>				<i>Register Compatibility Type: 365</i>			
<i>Bit 7</i>	<i>Bit 6</i>	<i>Bit 5</i>	<i>Bit 4</i>	<i>Bit 3</i>	<i>Bit 2</i>	<i>Bit 1</i>	<i>Bit 0</i>
<i>Data</i>							

#### A.2 Chip Control Registers

<i>Register Name: Chip Revision</i>				<i>Register Per: chip</i>			
<i>Index: 00h</i>				<i>Register Compatibility Type: 365</i>			
<i>Bit 7</i>	<i>Bit 6</i>	<i>Bit 5</i>	<i>Bit 4</i>	<i>Bit 3</i>	<i>Bit 2</i>	<i>Bit 1</i>	<i>Bit 0</i>
Interface ID		0	0	Revision			
R:10		R:0	R:0	R:0010 <sup>a</sup>			

<sup>a</sup> Value for the current stepping only.

<i>Register Name: Interface Status</i>				<i>Register Per: socket</i>			
<i>Index: 01h</i>				<i>Register Compatibility Type: 365</i>			
<i>Bit 7</i>	<i>Bit 6</i>	<i>Bit 5</i>	<i>Bit 4</i>	<i>Bit 3</i>	<i>Bit 2</i>	<i>Bit 1</i>	<i>Bit 0</i>
-VPP_VALID		RDY	WP	-CD2	-CD1	BVD2	BVD1
V <sub>PP</sub> Valid	Card Power On	Ready/Busy*	Write Protect	Card Detect		Battery Voltage Detect	
R <sup>a</sup>	R:0	R <sup>b</sup>	R <sup>c</sup>	R <sup>d</sup>		R <sup>e</sup>	



- <sup>a</sup> Bit 7 is the inversion of the value of the -VPP\_VALID pin (see page 17).
- <sup>b</sup> Bit 5 is the value of the RDY/-IREQ pin (see page 19).
- <sup>c</sup> Bit 4 is the value of the WP/-IOIS16 pin (see page 19).
- <sup>d</sup> Bits 3:2 are the inversion of the values of the -CD1 and -CD2 pins (see page 20).
- <sup>e</sup> Bits 1:0 are the values of the BVD1/-STSCHG and BVD2/-SPKR pins (see page 20).

<b>Register Name: Power Control</b>				<i>Register Per: socket</i>			
<b>Index: 02h</b>				<i>Register Compatibility Type: 365</i>			
<i>Bit 7</i>	<i>Bit 6</i>	<i>Bit 5</i>	<i>Bit 4</i>	<i>Bit 3</i>	<i>Bit 2</i>	<i>Bit 1</i>	<i>Bit 0</i>
Card Enable	Compatibility Bit	Auto-Power	V <sub>CC</sub> Power	Compatibility Bits		V <sub>PP1</sub> Power	
RW:0	RW:0	RW:0	RW:0	RW:00		RW:00	

<b>Register Name: Interrupt and General Control</b>				<i>Register Per: socket</i>			
<b>Index: 03h</b>				<i>Register Compatibility Type: 365</i>			
<i>Bit 7</i>	<i>Bit 6</i>	<i>Bit 5</i>	<i>Bit 4</i>	<i>Bit 3</i>	<i>Bit 2</i>	<i>Bit 1</i>	<i>Bit 0</i>
Ring Indicate Enable	Card Reset*	Card Is I/O	Enable Management Interrupts	Card IRQ Select			
RW:0	RW:0	RW:0	RW:0	RW:0000			

<b>Register Name: Card Status Change</b>				<i>Register Per: socket</i>			
<b>Index: 04h</b>				<i>Register Compatibility Type: 365</i>			
<i>Bit 7</i>	<i>Bit 6</i>	<i>Bit 5</i>	<i>Bit 4</i>	<i>Bit 3</i>	<i>Bit 2</i>	<i>Bit 1</i>	<i>Bit 0</i>
0	0	0	0	Card Detect Change	Ready Change	Battery Warning Change	Battery Dead Or Status Change
R:0	R:0	R:0	R:0	R:0	R:0	R:0	R:0

<b>Register Name: Management Interrupt Configuration</b>				<i>Register Per: socket</i>			
<b>Index: 05h</b>				<i>Register Compatibility Type: 365</i>			
<i>Bit 7</i>	<i>Bit 6</i>	<i>Bit 5</i>	<i>Bit 4</i>	<i>Bit 3</i>	<i>Bit 2</i>	<i>Bit 1</i>	<i>Bit 0</i>
Management IRQ Select				Card Detect Enable	Ready Enable	Battery Warning Enable	Battery Dead Or Status Change Enable
RW:0000				RW:0	RW:0	RW:0	RW:0



<b>Register Name: Mapping Enable</b>						<i>Register Per: socket</i>	
<b>Index: 06h</b>						<i>Register Compatibility Type: 365</i>	
<i>Bit 7</i>	<i>Bit 6</i>	<i>Bit 5</i>	<i>Bit 4</i>	<i>Bit 3</i>	<i>Bit 2</i>	<i>Bit 1</i>	<i>Bit 0</i>
I/O Map 1 Enable	I/O Map 0 Enable	MEMCS16 Full Decode	Memory Map 4 Enable	Memory Map 3 Enable	Memory Map 2 Enable	Memory Map 1 Enable	Memory Map 0 Enable
RW:0	RW:0	RW:0	RW:0	RW:0	RW:0	RW:0	RW:0

### A.3 I/O Window Mapping Registers

<b>Register Name: I/O Window Control</b>						<i>Register Per: socket</i>	
<b>Index: 07h</b>						<i>Register Compatibility Type: 365</i>	
<i>Bit 7</i>	<i>Bit 6</i>	<i>Bit 5</i>	<i>Bit 4</i>	<i>Bit 3</i>	<i>Bit 2</i>	<i>Bit 1</i>	<i>Bit 0</i>
Timing Register Select 1	Compatibility Bit	Auto-Size I/O Window 1	I/O Window 1 Size	Timing Register Select 0	Compatibility Bit	Auto-Size I/O Window 0	I/O Window 0 Size
RW:0	RW:0	RW:0	RW:0	RW:0	RW:0	RW:0	RW:0

<b>Register Name: System I/O Map 0–1 Start Address Low</b>						<i>Register Per: socket</i>	
<b>Index: 08h, 0Ch</b>						<i>Register Compatibility Type: 365</i>	
<i>Bit 7</i>	<i>Bit 6</i>	<i>Bit 5</i>	<i>Bit 4</i>	<i>Bit 3</i>	<i>Bit 2</i>	<i>Bit 1</i>	<i>Bit 0</i>
Start Address 7:0							
RW:00000000							

<b>Register Name: System I/O Map 0–1 Start Address High</b>						<i>Register Per: socket</i>	
<b>Index: 09h, 0Dh</b>						<i>Register Compatibility Type: 365</i>	
<i>Bit 7</i>	<i>Bit 6</i>	<i>Bit 5</i>	<i>Bit 4</i>	<i>Bit 3</i>	<i>Bit 2</i>	<i>Bit 1</i>	<i>Bit 0</i>
Start Address 15:8							
RW:00000000							

<b>Register Name: System I/O Map 0–1 End Address Low</b>						<i>Register Per: socket</i>	
<b>Index: 0Ah, 0Eh</b>						<i>Register Compatibility Type: 365</i>	
<i>Bit 7</i>	<i>Bit 6</i>	<i>Bit 5</i>	<i>Bit 4</i>	<i>Bit 3</i>	<i>Bit 2</i>	<i>Bit 1</i>	<i>Bit 0</i>
End Address 7:0							
RW:00000000							



<b>Register Name: System I/O Map 0-1 End Address High</b>							<i>Register Per: socket</i>
<b>Index: 0Bh, 0Fh</b>							<i>Register Compatibility Type: 365</i>
Bit 7	Bit 6	Bit 5	Bit 4	Bit 3	Bit 2	Bit 1	Bit 0
End Address 15:8							
RW:00000000							

<b>Register Name: Card I/O Map 0-1 Offset Address Low</b>							<i>Register Per: socket</i>
<b>Index: 36h, 38h</b>							<i>Register Compatibility Type: ext.</i>
Bit 7	Bit 6	Bit 5	Bit 4	Bit 3	Bit 2	Bit 1	Bit 0
Offset Address 7:1							0 <sup>a</sup>
RW:00000000							RW:0

<sup>a</sup> This bit must be programmed to '0'.

<b>Register Name: Card I/O Map 0-1 Offset Address High</b>							<i>Register Per: socket</i>
<b>Index: 37h, 39h</b>							<i>Register Compatibility Type: ext.</i>
Bit 7	Bit 6	Bit 5	Bit 4	Bit 3	Bit 2	Bit 1	Bit 0
Offset Address 15:8							
RW:00000000							

#### A.4 Memory Window Mapping Registers

<b>Register Name: System Memory Map 0-4 Start Address Low</b>							<i>Register Per: socket</i>
<b>Index: 10h, 18h, 20h, 28h, 30h</b>							<i>Register Compatibility Type: 365</i>
Bit 7	Bit 6	Bit 5	Bit 4	Bit 3	Bit 2	Bit 1	Bit 0
Start Address 19:12							
RW:00000000							

<b>Register Name: System Memory Map 0-4 Start Address High</b>							<i>Register Per: socket</i>
<b>Index: 11h, 19h, 21h, 29h, 31h</b>							<i>Register Compatibility Type: 365</i>
Bit 7	Bit 6	Bit 5	Bit 4	Bit 3	Bit 2	Bit 1	Bit 0
Window Data Size	Compatibility Bit	Scratchpad Bits		Start Address 23:20			
RW:0	RW:0	RW:00		RW:0000			



<b>Register Name: System Memory Map 0-4 End Address Low</b> <b>Index: 12h, 1Ah, 22h, 2Ah, 32h</b>							<i>Register Per: socket</i> <i>Register Compatibility Type: 365</i>
Bit 7	Bit 6	Bit 5	Bit 4	Bit 3	Bit 2	Bit 1	Bit 0
End Address 19:12							
RW:00000000							

<b>Register Name: System Memory Map 0-4 End Address High</b> <b>Index: 13h, 1Bh, 23h, 2Bh, 33h</b>							<i>Register Per: socket</i> <i>Register Compatibility Type: 365</i>
Bit 7	Bit 6	Bit 5	Bit 4	Bit 3	Bit 2	Bit 1	Bit 0
Card Timer Select		Scratchpad Bits			End Address 23:20		
RW:00		RW:00			RW:0000		

<b>Register Name: Card Memory Map 0-4 Offset Address Low</b> <b>Index: 14h, 1Ch, 24h, 2Ch, 34h</b>							<i>Register Per: socket</i> <i>Register Compatibility Type: 365</i>
Bit 7	Bit 6	Bit 5	Bit 4	Bit 3	Bit 2	Bit 1	Bit 0
Offset Address 19:12							
RW:00000000							

<b>Register Name: Card Memory Map 0-4 Offset Address High</b> <b>Index: 15h, 1Dh, 25h, 2Dh, 35h</b>							<i>Register Per: socket</i> <i>Register Compatibility Type: 365</i>
Bit 7	Bit 6	Bit 5	Bit 4	Bit 3	Bit 2	Bit 1	Bit 0
Write Protect	REG Setting	Offset Address 25:20					
RW:0	RW:0	RW:000000					





## A.5 Extension Registers

Register Name: <b>Misc Control 1</b>							Register Per: socket
Index: <b>16h</b>							Register Compatibility Type: ext.
Bit 7	Bit 6	Bit 5	Bit 4	Bit 3	Bit 2	Bit 1	Bit 0
Inpack Enable	Scratchpad Bits		Speaker Enable	Pulse System IRQ	Pulse Management Interrupt	V <sub>CC</sub> 3.3V	5 V Detect (CL-PD6710) Reserved (VG-PD6722)
RW:0	RW:00		RW:0	RW:0	RW:0	RW:0	R:X W:0

Register Name: <b>FIFO Control</b>							Register Per: socket
Index: <b>17h</b>							Register Compatibility Type: ext.
Bit 7	Bit 6	Bit 5	Bit 4	Bit 3	Bit 2	Bit 1	Bit 0
Empty Write FIFO	Scratchpad Bits <sup>a</sup>						
RW	RW:0000000						

<sup>a</sup> Because a write will flush the FIFO, these scratchpad bits should be used only when card activity is guaranteed not to occur.

Register Name: <b>Misc Control 2</b>							Register Per: chip
Index: <b>1Eh</b>							Register Compatibility Type: ext.
Bit 7	Bit 6	Bit 5	Bit 4	Bit 3	Bit 2	Bit 1	Bit 0
IRQ15 Is RI Out	DMA System (VG-PD6722)	Three-State Bit 7	Drive LED Enable	5V Core	Suspend	Low-Power Dynamic Mode	Bypass Frequency Synthesizer
RW:0	RW:0	RW:0	RW:0	RW:0	RW:0	RW:1	RW:0

Register Name: <b>Chip Information</b>							Register Per: chip
Index: <b>1Fh</b>							Register Compatibility Type: ext.
Bit 7	Bit 6	Bit 5	Bit 4	Bit 3	Bit 2	Bit 1	Bit 0
Host-Adapter Identification		Dual/Single Socket*	VG-PD67XX Revision Level			Reserved	
R:11		R:n <sup>a</sup>	R:nnnn <sup>b</sup>			R:n <sup>c</sup>	

<sup>a</sup> The value for CL-PD6710 is '0', and the value for VG-PD6722 is '1'.

<sup>b</sup> This read-only value depends on the revision level of the VG-PD67XX chip.

<sup>c</sup> The value for VG-PD6722 is '1'.



<b>Register Name: ATA Control</b>						<i>Register Per:</i> socket	
<b>Index: 26h</b>						<i>Register Compatibility Type:</i> ext.	
<i>Bit 7</i>	<i>Bit 6</i>	<i>Bit 5</i>	<i>Bit 4</i>	<i>Bit 3</i>	<i>Bit 2</i>	<i>Bit 1</i>	<i>Bit 0</i>
A25/CSEL	A24/M/S*	A23/VU	A22	A21	Scratchpad Bit	Speaker Is LED Input	ATA Mode
RW:0	RW:0	RW:0	RW:0	RW:0	RW:0	RW:0	RW:0

<b>Register Name: Extended Index (VG-PD6722 only)</b>				<i>Register Per:</i> socket			
<b>Index: 2Eh</b>				<i>Register Compatibility Type:</i> ext.			
<i>Bit 7</i>	<i>Bit 6</i>	<i>Bit 5</i>	<i>Bit 4</i>	<i>Bit 3</i>	<i>Bit 2</i>	<i>Bit 1</i>	<i>Bit 0</i>
Extended Index							
RW:00000000							

<b>Register Name: Extended Data (VG-PD6722 only)</b>				<i>Register Per:</i> socket			
<b>Index: 2Fh</b>				<i>Register Compatibility Type:</i> ext.			
<i>Bit 7</i>	<i>Bit 6</i>	<i>Bit 5</i>	<i>Bit 4</i>	<i>Bit 3</i>	<i>Bit 2</i>	<i>Bit 1</i>	<i>Bit 0</i>
Extended Data							

<b>Register Name: Data Mask 0 (VG-PD6722 only)</b>				<i>Register Per:</i> socket			
<b>Index: 2Fh</b>				<i>Register Compatibility Type:</i> ext.			
<i>Extended Index: 01h</i>							
<i>Bit 7</i>	<i>Bit 6</i>	<i>Bit 5</i>	<i>Bit 4</i>	<i>Bit 3</i>	<i>Bit 2</i>	<i>Bit 1</i>	<i>Bit 0</i>
Data Mask Select 0							
RW:00000000							

<b>Register Name: Data Mask 1 (VG-PD6722 only)</b>				<i>Register Per:</i> socket			
<b>Index: 2Fh</b>				<i>Register Compatibility Type:</i> ext.			
<i>Extended Index: 02h</i>							
<i>Bit 7</i>	<i>Bit 6</i>	<i>Bit 5</i>	<i>Bit 4</i>	<i>Bit 3</i>	<i>Bit 2</i>	<i>Bit 1</i>	<i>Bit 0</i>
Data Mask Select 1							
RW:00000000							



<b>Register Name: Extension Control 1 (VG-PD6722 only)</b> Index: 2Fh				Extended Index: 03h		Register Per: socket Register Compatibility Type: ext.	
Bit 7	Bit 6	Bit 5	Bit 4	Bit 3	Bit 2	Bit 1	Bit 0
DMA Enable		Pull-up Control	Reserved		LED Activity Enable	Auto Power Clear Disable	V <sub>CC</sub> Power Lock
RW:00		RW:0	RW:00		RW:0	RW:0	RW:0

<b>Register Name: Maximum DMA Acknowledge Delay (VG-PD6722 only)</b> Index: 2Fh				Extended Index: 04h		Register Per: socket Register Compatibility Type: ext.	
Bit 7	Bit 6	Bit 5	Bit 4	Bit 3	Bit 2	Bit 1	Bit 0
Maximum DMA Acknowledge Delay							
RW:00000000							

<b>Register Name: External Data (VG-PD6722 only)</b> Index: 2Fh				Extended Index: 0Ah		Register Per: socket Register Compatibility Type: ext.	
Bit 7	Bit 6	Bit 5	Bit 4	Bit 3	Bit 2	Bit 1	Bit 0
External Data 7	External Data 6	External Data 5	External Data 4	External Data 3	External Data 2	External Data 1	External Data 0
RW:0	RW:0	RW:0	RW:0	RW:0	RW:0	RW:0	RW:0

<b>Register Name: External Data (VG-PD6722 only)</b> Index: 6Fh				Extended Index: 0Ah		Register Per: socket Register Compatibility Type: ext.	
Bit 7	Bit 6	Bit 5	Bit 4	Bit 3	Bit 2	Bit 1	Bit 0
External Data 7	External Data 6	External Data 5	External Data 4	External Data 3 or B_VS2 Input	External Data 2 or B_VS1 Input	External Data 1 or A_VS2 Input	External Data 0 or A_VS1 Input
RW:0	RW:0	RW:0	RW:0	R:0	R:0	R:0	R:0

<b>Register Name: Extension Control 2 (VG-PD6722 only)</b> Index: 2Fh and 6Fh				Extended Index: 0Bh		Register Per: socket Register Compatibility Type: ext.	
Bit 7	Bit 6	Bit 5	Bit 4	Bit 3	Bit 2	Bit 1	Bit 0
Reserved		Active-high GPSTB	GPSTB on IOW*	GPSTB on IOR*	Totem-pole GPSTB	Reserved	
RW:00		RW:0	RW:0	RW:0	RW:0	RW:00	



## A.6 Timing Registers

<i>Register Name:</i> <b>Setup Timing 0–1</b>				<i>Register Per:</i> socket			
<i>Index:</i> <b>3Ah, 3Dh</b>				<i>Register Compatibility Type:</i> 365			
<i>Bit 7</i>	<i>Bit 6</i>	<i>Bit 5</i>	<i>Bit 4</i>	<i>Bit 3</i>	<i>Bit 2</i>	<i>Bit 1</i>	<i>Bit 0</i>
Setup Prescalar Select			Setup Multiplier Value				
RW:00			RW:000001				

<i>Register Name:</i> <b>Command Timing 0–1</b>				<i>Register Per:</i> socket			
<i>Index:</i> <b>3Bh, 3Eh</b>				<i>Register Compatibility Type:</i> 365			
<i>Bit 7</i>	<i>Bit 6</i>	<i>Bit 5</i>	<i>Bit 4</i>	<i>Bit 3</i>	<i>Bit 2</i>	<i>Bit 1</i>	<i>Bit 0</i>
Command Prescalar Select			Command Multiplier Value				
RW:00			RW:000110/001111 <sup>a</sup>				

<sup>a</sup> Timing set 0 (index 3Bh) resets to 06h for socket timing equal to standard AT-bus-based cycle times. Timing set 1 (3Eh) resets to 0Fh for socket timings equal to standard AT-bus timing using one additional wait state.

<i>Register Name:</i> <b>Recovery Timing 0–1</b>				<i>Register Per:</i> socket			
<i>Index:</i> <b>3Ch, 3Fh</b>				<i>Register Compatibility Type:</i> 365			
<i>Bit 7</i>	<i>Bit 6</i>	<i>Bit 5</i>	<i>Bit 4</i>	<i>Bit 3</i>	<i>Bit 2</i>	<i>Bit 1</i>	<i>Bit 0</i>
Recovery Prescalar Select			Recovery Multiplier Value				
RW:00			RW:000011				



## INDEX

### Numerics

+5V 20  
5V Core bit 61

### A

A[25:0] 16  
A\_ pin name 16  
    See also the pin name  
A21 bit 64  
A22 bit 64  
A23/VU bit 64  
A24/M/S\* bit 64  
A25/CSEL bit 64  
AC specifications 91–109  
Active-high GPSTB bit 71  
AEN 13  
ALE 12  
ATA Control register 64  
ATA mode  
    description 75  
    overview 29  
    pin cross reference 75  
ATA Mode bit 64  
Auto Power Clear Disable bit 66  
Auto-Power bit 41  
Auto-Size I/O Window 0 bit 49  
Auto-Size I/O Window 1 bit 49

### B

B\_ pin name 16  
    See also the pin name  
Battery Dead Or Status Change bit 44  
Battery Dead Or Status Change Enable bit 45  
Battery Voltage Detect bits 38  
Battery Warning Change bit 44  
Battery Warning Enable bit 45  
BBS (bulletin board system) 114  
bus sizing 29  
BVD1/-STSCHG/-RI 19  
BVD2/-SPKR/-LED 18  
Bypass Frequency Synthesizer bit 61

### C

C\_SEL 15  
Card Detect bits 38  
Card Detect Change bit 44  
Card Detect Enable bit 45  
Card Enable bit 41  
Card I/O Map 0–1 Address Offset High registers 52

Card I/O Map 0–1 Address Offset Low registers 52  
Card IRQ Select bits 42  
Card Is I/O bit 42  
Card Memory Map 0–4 Offset Address High registers 56  
Card Memory Map 0–4 Offset Address Low registers 56  
Card Power On bit 39  
Card Reset\* bit 43  
Card Status Change register 44  
Card Timer Select bits 55  
-CD[2:1] 18  
-CE[2:1] 18  
Chip Identification bits. See Amphus Host-Adapter Identification bits  
Chip Information register 63  
Chip Revision register 37  
Amphus Host-Adapter Identification bits 63  
CLK 15  
VG-PD67XX Revision Level bits 63  
Command Multiplier Value bits 73  
Command Prescalar Select bits 73  
Command Timing 0–1 registers 73  
conventions  
    bit naming 32  
    general 7  
    numbers and units 7  
    pin naming 11  
    register headings 32  
CORE\_VDD 20

### D

D[15:0] 16  
Data Mask 0–1 register 66  
Data Mask Select 0–1 bits 66  
Data register 36  
DC specifications 87–90  
Device Index bit 33  
DMA Control register. See Extension Control 1 register  
DMA Enable bits 67  
DMA mode  
    configuring 84–86  
    description 83  
    overview 30  
DMA Read Cycle timing 105  
DMA Request timing 109  
DMA System bit 62  
DMA Write Cycle timing 107  
Drive LED Enable bit 61  
Dual/Single Socket\* bit 63



## E

Empty Write FIFO bit 60  
Enable Manage Int bit 42  
End Address  
    15:8 bits 51  
    19:12 bits 55  
    23:20 bits 55  
    7:0 bits 51  
Extended Data register 65  
Extended Index register 65  
Extended Register Index bits 65  
Extension Control 1 register 66  
Extension Control 2 register 71  
External Data bits 69–70  
External Data register 69

## F

FIFO Control register 60  
form factor 1–2, 110, 112  
functional blocks 25

## G

general-purpose strobe  
    control 77  
    description 77–80  
    example implementations 79  
    overview 26  
    suspend mode 80  
General-Purpose Strobe timing 96  
GND 20  
GPSTB 19  
GPSTB on IOR\* bit 71  
GPSTB on IOW\* bit 71

## H

host access to registers 30

## I

I/O Map 0 Enable bit 48  
I/O Map 0–1 Start Address High registers 50  
I/O Map 1 Enable bit 48  
I/O Window 0 Size bit 49  
I/O Window 1 Size bit 49  
I/O Window Control register 49  
IDE 75  
Index register 33  
-INPACK 17  
Inpack Enable bit 59  
Input Clock specification 97  
Interface ID bits 37

Interface Status register 38  
Interrupt and General Control register 42  
interrupts 25  
-INTR 14  
IOCHRDY 13  
IOCS16\* 13  
-IOIS16 17  
IOR\* 12  
-IORD 17  
IOW\* 12  
-IOWR 17  
-IREQ 17  
IRQ Level bits. See Card IRQ Select bits  
IRQ[14, 11, 7, 5:3] 13  
IRQ10 13  
IRQ10 as DRQ, description 26  
IRQ12 as LED\_OUT\*, description 26  
IRQ12/LED\_OUT\* 14  
IRQ15 as RI\_OUT\*, description 26  
IRQ15 Is RI Out bit 62  
IRQ15/RI\_OUT\* 14  
IRQ9 13  
IRQ9 as DACK\*, description 26  
ISA bus interface pins 12–15  
ISA bus timing 92  
ISA\_VCC 15

## L

LA[23:17] 12  
-LED 18  
LED Activity Enable bit 66  
LED\_OUT\* 14  
Low-Power Dynamic mode 27  
Low-Power Dynamic Mode bit 61

## M

Management Interrupt Configuration register 45  
Management IRQ Select bits 46  
Mapping Enable register 47  
MEMCS16 Full Decode bit 47  
MEMCS16\* 13  
Memory Map  
    0 Enable bit 47  
    1 Enable bit 47  
    2 Enable bit 47  
    3 Enable bit 47  
    4 Enable bit 47  
MEMR\* 12  
MEMW\* 12  
Misc Control 1 register 58  
Misc Control 2 register 61



- N**  
 Normal Byte Read/Write timing 103
- O**  
 Odd Byte timing 104  
 -OE 16  
 Offset Address  
   15:8 bits 52  
   19:12 bits 56  
   25:20 bits 57  
   7:1 bits 52  
 ordering information 113
- P**  
 package  
   144-pin VQFP 110  
   208-pin PQFP 111  
   208-pin VQFP 112  
 PC Card  
   basics 22  
   bus timing calculations 98  
   Read/Write timing 102  
   socket timing 99  
   timing 29  
 PCMCIA 22  
 pin descriptions 8, 20  
 pin diagram  
   144-pin VQFP 9  
   208-pin PQFP or VQFP 10  
 pin usage summary 21  
 power consumption 28  
 Power Control register 40  
 power management 27  
 power-on  
   configuration 21  
   setup 31  
 Pull-up Control bit 67  
 Pulse Management Interrupt bit 58  
 Pulse Mode Interrupt timing 95  
 Pulse System IRQ bit 59  
 PWRGOOD 12
- R**  
 RDY/-IREQ 17  
 Ready Change bit 44  
 Ready Enable bit 45  
 Ready/Busy\* bit 39  
 Recovery Multiplier Value bits 74  
 Recovery Prescaler Select bits 74  
 Recovery Timing 0–1 registers 74
- REFRESH\* 12  
 -REG 16  
 REG Setting bit 57  
 Register Index bits 33  
 register summary tables 116–123  
 RESET 18  
 Reset timing 94  
 Revision bits 37  
 -RI 19  
 RI\_OUT\* 14  
 Ring Indicate Enable bit 43
- S**  
 SA[16:0] 12  
 SBHE\* 12  
 SD[15:0] 12  
 Setup Multiplier Value bits 72  
 Setup Prescaler Select bit 72  
 Setup Timing 0–1 registers 72  
 SLOT\_VCC. See SOCKET\_VCC  
 socket  
   accessing specific registers 33  
   register per 32  
 Socket Index bit 33  
 socket interface pins 16–19  
 socket power features 28  
 SOCKET\_VCC 19  
 Speaker Enable bit 59  
 Speaker Is LED Input bit 64  
 -SPKR 18  
 SPKR\_OUT\*/C\_SEL 15  
 Start Address  
   15:8 bits 50  
   19:12 bits 53  
   23:20 bits 54  
   7:0 bits 50  
 -STSCHG 19  
 Super-Suspend mode, description 27  
 Suspend bit 61  
 Suspend mode, description 27  
 System I/O Map 0–1  
   End Address High registers 51  
   End Address Low registers 51  
   Start Address Low registers 50  
 System Interrupt timing 95  
 System Memory Map 0–4  
   End Address High registers 55  
   End Address Low registers 54  
   Start Address High registers 54  
   Start Address Low registers 53



- T**
- Three-State Bit 7 bit 62
  - timing
    - DMA Read Cycle 105
    - DMA request 109
    - DMA Write Cycle 107
    - General-Purpose Strobe 96
    - ISA bus 92
    - Normal Byte Read/Write 103
    - Odd Byte 104
    - PC Card bus 98
    - PC Card Read/Write 102
    - PC Card socket 99
    - Pulse Mode Interrupt 95
    - Reset 94
    - System Interrupt 95
    - Word I/O Read/Write 100
  - Timing Register Select 0 bit 49
  - Timing Register Select 1 bit 50
  - Totem-pole GPSTB bit 71
- V**
- V<sub>CC</sub> 3.3V bit 58
  - V<sub>CC</sub> Power bit 41
  - V<sub>CC</sub> Power Lock bit 66
  - VCC\_3 20
  - VCC\_5 20
  - VDD. See CORE\_VDD
  - voltage sense 81–82
    - overview 27
  - V<sub>PP</sub> Valid bit 39
  - VPP\_PGM 20
  - VPP\_VALID 15
  - VPP\_VCC 20
  - V<sub>PP1</sub> Power bits 41
- W**
- WAIT 18
  - WE 17
  - Window Data Size bit 54
  - windowing 22
  - Word I/O Read/Write timing 100
  - WP/-IOIS16 17
  - write FIFO 29
  - Write Protect bit 38, 57
- Z**
- ZWS\* 14





**Notes**