

Intel® PC Card (PCMCIA) Controllers



Product Line Overview

Intel® PC Card controllers are highly integrated, small form factor, power-efficient devices that support industry standards, including PCMCIA 2.1 and JEIDA 4.1, with ExCA* compatibility and ATA disk interface support. They provide an efficient way to install software in a wide variety of products, including routers, bridges, network switches, servers, digital subscriber line access multiplexers (DSLAM), customer premises equipment (CPE) multi-service access devices, portable and wireless equipment, navigation systems, printers, and test equipment. Intel dual-slot controllers feature ZV (Zoom Video) support for video and multimedia applications.

The Intel family of single-chip PC Card controllers supports single-slot (Intel® PD6710) and dual-slot (Intel® PD6722) ISA-to-PC Card

interfaces and a dual-slot PCI-to-PC Card interface (Intel® PD6729). All include programmable features, including suspend mode, memory and I/O windows, and card access cycle timing. In addition, Intel PC Card controllers are designed with sophisticated power saving features, including support for mixed voltage and automatic low-power dynamic mode. Energy-efficient mixed voltage technology can reduce system power consumption by 50 percent or more compared to conventional designs.

PC Card controllers provide a flexible, compact, and cost-effective software transport solution for communications devices and embedded systems that require a combination of field upgradability, small form factor, and power savings.

Intel® PD6710/ Intel® PD6722 ISA-to-PC Card Controllers

Product Highlights

- Single-chip PC Card controllers
- Supports single or dual PC Card sockets
- Compliant with PCMCIA 2.1, JEIDA 4.1
- 82365SL-compatible register set
- Automatic low-power mode
- Programmable suspend mode
- Hardware-enabled super-suspend mode
- 5 programmable memory windows per socket
- 2 programmable I/O windows per socket
- Programmable card access cycle timing
- Supports 8- or 16-bit system bus interface
- Supports 8- and 16-bit PC Card interface
- Supports ATA disk interface
- DMA support (Intel® PD6722)
- Card-voltage sensing
- PC Card activity indicator
- 3.3/5.0 V mixed-voltage operation
- Single socket: 144-pin LQFP
- Dual socket: 208-pin MQFP and LQFP

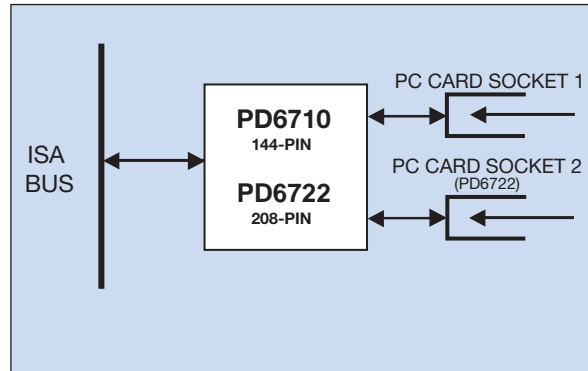

Product Overview

The Intel® PD6710 and Intel® PD6722 PC Card controllers are single-chip solutions that provide direct connection to the ISA (PC-AT) bus and one (Intel PD6710) or two (Intel PD6722) PC Card sockets. PC Card interfaces are useful for supporting software updates, memory expansion, configuration storage and event logs, and both wireless and wire-line communications in applications including customer premises equipment (CPE), routers, network switches, remote access servers, DSL access multiplexers (DSLAMs), and intelligent hand-held devices. The controllers are optimized for embedded applications where reduced form factor and low-power consumption are important design considerations. Excluding the socket connectors, the Intel PD6710 single-socket controller occupies less than 1.5 square inches, including power control logic. The Intel PD6722 controller with power control logic occupies less than two square inches.

The controllers accommodate various PC Card functions including wireless, flash, and 10/100 Ethernet. They are fully compatible with PCMCIA 2.1 and JEIDA 4.1 standards. The controllers feature mixed voltage technology that can significantly reduce system power consumption. Suspend mode stops the internal clock. Automatic low-power dynamic mode stops transactions on the PCMCIA bus, stops internal clock distribution, and turns off internal circuitry. Fully buffered PCMCIA signals allow hot insertion and removal without requiring external logic to buffer incoming and outgoing signals, and allow-power consumption to be controlled by limiting signal transitions on the PCMCIA bus.

Intel® PD6729 PCI-to-PC Card Controller

Product Highlights

- Single-chip PC Card controller
- Supports dual PC Card sockets
- Compliant with PCI 2.1
- Compliant with PCMCIA 2.1, JEIDA 4.1
- 82365SL-compatible register set
- Automatic low-power mode
- Programmable suspend mode
- 5 programmable memory windows per socket
- 2 programmable I/O windows per socket
- Programmable card access cycle timing
- Supports 8- or 16-bit PC Card interface
- Supports ATA disk interface
- Automatic flash timing support
- Multimedia capability with Zoom Video Port
- Card-voltage sense support
- PC Card activity indicator
- +3.3 V, +5 V, or 3.3/5.0 V mixed-voltage operation
- Supports PC Card low-voltage card specification
- 208-pin MQFP and LQFP

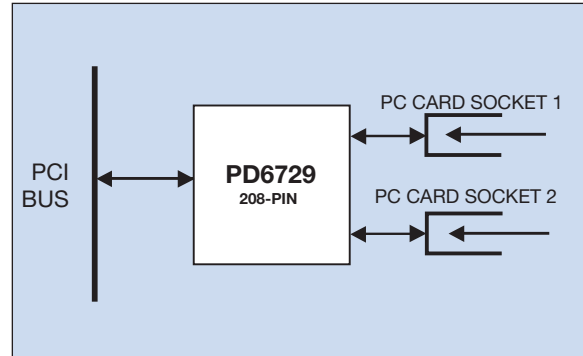

Product Overview

The Intel® PD6729 PCI-to-PC Card controller is a single-chip solution that provides direct connection to the PCI bus. It is optimized for embedded applications where reduced form factor and low-power consumption are important design objectives. Applications include customer premises equipment (CPE), routers, network switches, remote access servers, DSL access multiplexers (DSLAMs), and intelligent hand-held devices. The PC Card interface can be used to support software updates, memory expansion, configuration storage and event logs, and both wireless and wire-line communications.

The Intel PD6729 accommodates various PC Card functions, including wireless, flash memory, and 10/100 Ethernet. It is capable of controlling two fully independent PC Card sockets and is fully compatible with PCMCIA 2.1 and JEIDA 4.1. Fully buffered PCMCIA signals require no external logic to buffer incoming and outgoing signals, and allow power consumption to be controlled by limiting signal transitions on the PCMCIA bus. The controller features energy efficient mixed voltage technology that can significantly reduce system power consumption. Suspend mode stops the internal clock, and automatic low-power dynamic mode stops transactions on the PCMCIA bus, stops internal clock distribution, and turns off internal circuitry.

Ordering Information

Contact an authorized Intel distributor for complete ordering details.

Product	Order Code
Intel® PD6710-VC-B	DZPD6710VCB
Intel® PD6722-QC-CE	SPD6722QCCE
Intel® PD6722-VC-CE	DZPD6722VCCE
Intel® PD6729-QC-E	SPD6729QCE
Intel® PD6729-VC-E	DZPD6729VCE
Intel® PDK6710 Evaluation Kit	PDK6710ADM12
Intel® PDK6722 Evaluation Kit	PDK6722ADM16
Intel® PDK6729 Evaluation Kit	PDK6729ADM14

Literature information

Intel® PC Card (PCMCIA) Controllers Product Brief	279023-002
Intel® CD1400 and Intel® CD1865 Serial Controllers Product Brief	279022-002
Intel® CD1283 and Intel® CD1284 Parallel Controllers Product Brief	279034-002
Intel® WAN Controllers Product Brief	273527-001
Interconnect Devices Product Selection and Application Guide	279037-002
Interconnect Devices Basis to Intel Conversion Chart	279036-002
Intel® Interconnect Devices Family Brochure	273544-001

Intel Access

Developer's Site	developer.intel.com
Networking & Communications Building Blocks	www.intel.com/design/interconnect
Other Intel Support:	developer.intel.com/design/litcentr
Intel Literature Center	(800) 548-4725 7 a.m. to 7 p.m. CST (U.S. and Canada) International locations please contact your local sales office.
General Information Hotline	(800) 628-8686 or (916) 356-3104 5 a.m. to 5 p.m. PST developer.intel.com/design/network

Information in this document is provided in connection with Intel products. No license, express or implied, by estoppel or otherwise, to any intellectual property rights is granted by this document. Except as provided in Intel's Terms and Conditions of Sale for such products, Intel assumes no liability whatsoever, and Intel disclaims any express or implied warranty, relating to sale and/or use of Intel products including liability or warranties relating to fitness for a particular purpose, merchantability, or infringement of any patent, copyright or other intellectual property right. Intel products are not intended for use in medical, life saving, or life sustaining applications. Intel may make changes to specifications and product descriptions at any time, without notice.

Designers must not rely on the absence or characteristics of any features or instructions marked "reserved" or "unrefined." Intel reserves these for future definition and shall have no responsibility whatsoever for conflicts or incompatibilities arising from future changes to them.

*Other names and brands may be claimed as the property of others.

Intel is a trademark or registered trademark of Intel Corporation or its subsidiaries in the United States and other countries.

For more information, visit the Intel Web site at: developer.intel.com



UNITED STATES AND CANADA
Intel Corporation
Robert Noyce Bldg.
2200 Mission College Blvd.
P.O. Box 58119
Santa Clara, CA 95052-8119
USA

EUROPE
Intel Corporation (UK) Ltd.
Pipers Way
Swindon
Wiltshire SN3 1RJ
UK

ASIA-PACIFIC
Intel Semiconductor Ltd.
32/F Two Pacific Place
88 Queensway, Central
Hong Kong, SAR

JAPAN
Intel Kabushiki Kaisha
P.O. Box 115 Tsukuba-gakuen
5-6 Tokodai, Tsukuba-shi
Ibaraki-ken 305
Japan

SOUTH AMERICA
Intel Semicondutores do Brazil
Rue Florida, 1703-2 and CJ22
CEP 04565-001 Sao Paulo-SP
Brazil