

THESE SCHEMATICS ARE PROVIDED AS A DESIGN GUIDE ONLY.
 VADEM ASSUMES NO RESPONSIBILITY FOR FINAL SYSTEM DESIGN.

FILE=230CFG2.SCH

VADEM		
Title VG-230 SAMPLE SCHEMATICS - CONFIG. 2		
Size B	Document Number	Rev 4
Date: Wednesday, March 17, 2004	Sheet 1 of 7	

VG-230 - CONFIGURATION 2

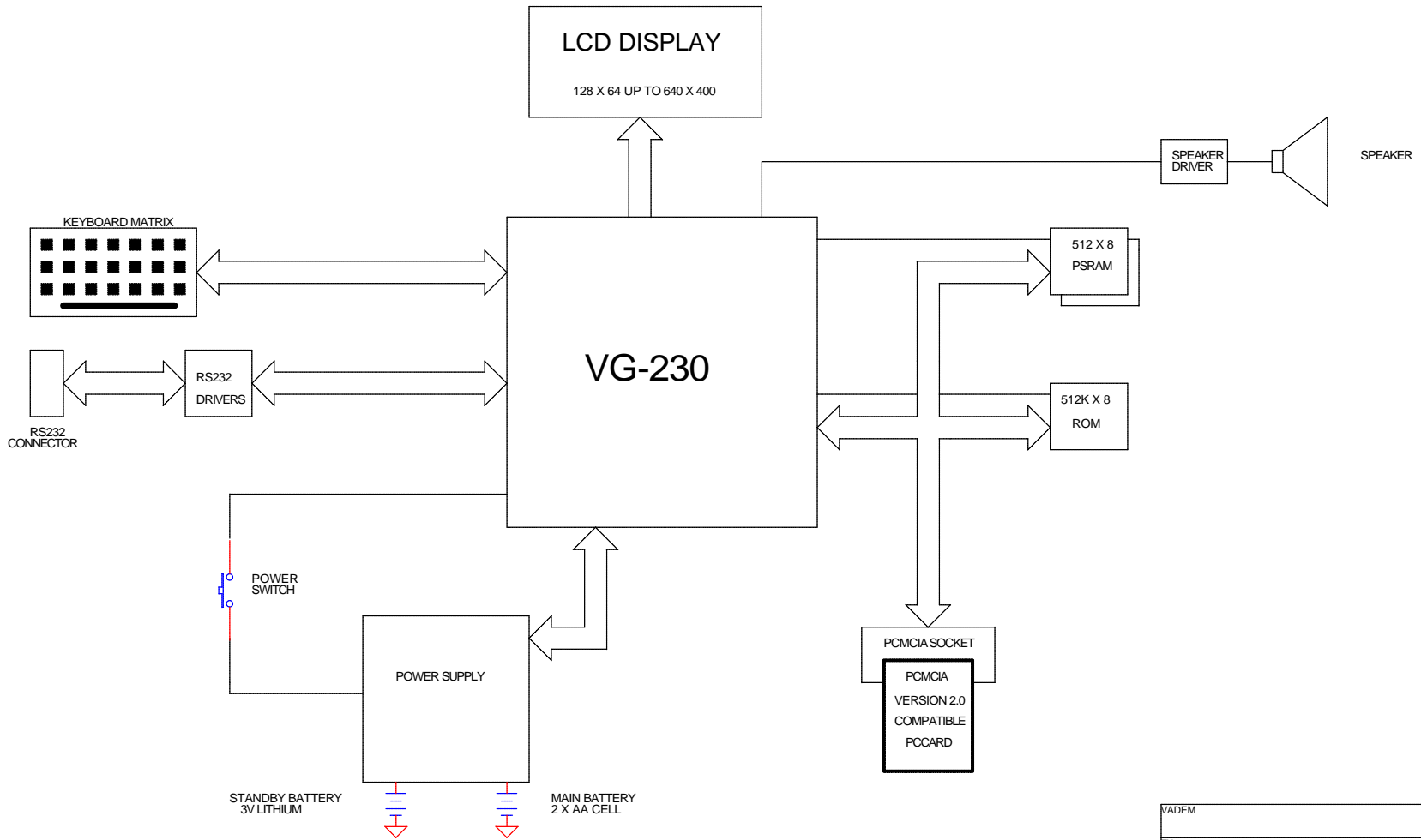

THESE SCHEMATICS ARE PROVIDED AS A DESIGN GUIDE ONLY.
 AMPHUS/VADEM ASSUMES NO RESPONSIBILITY FOR FINAL SYSTEM DESIGN.

VADEM		
Title VG-230 CONFIGURATION 2 - BLOCK DIAGRAM		
Size B	Document Number	Rev 4
Date: Wednesday, March 31, 2004		Sheet 2 of 7

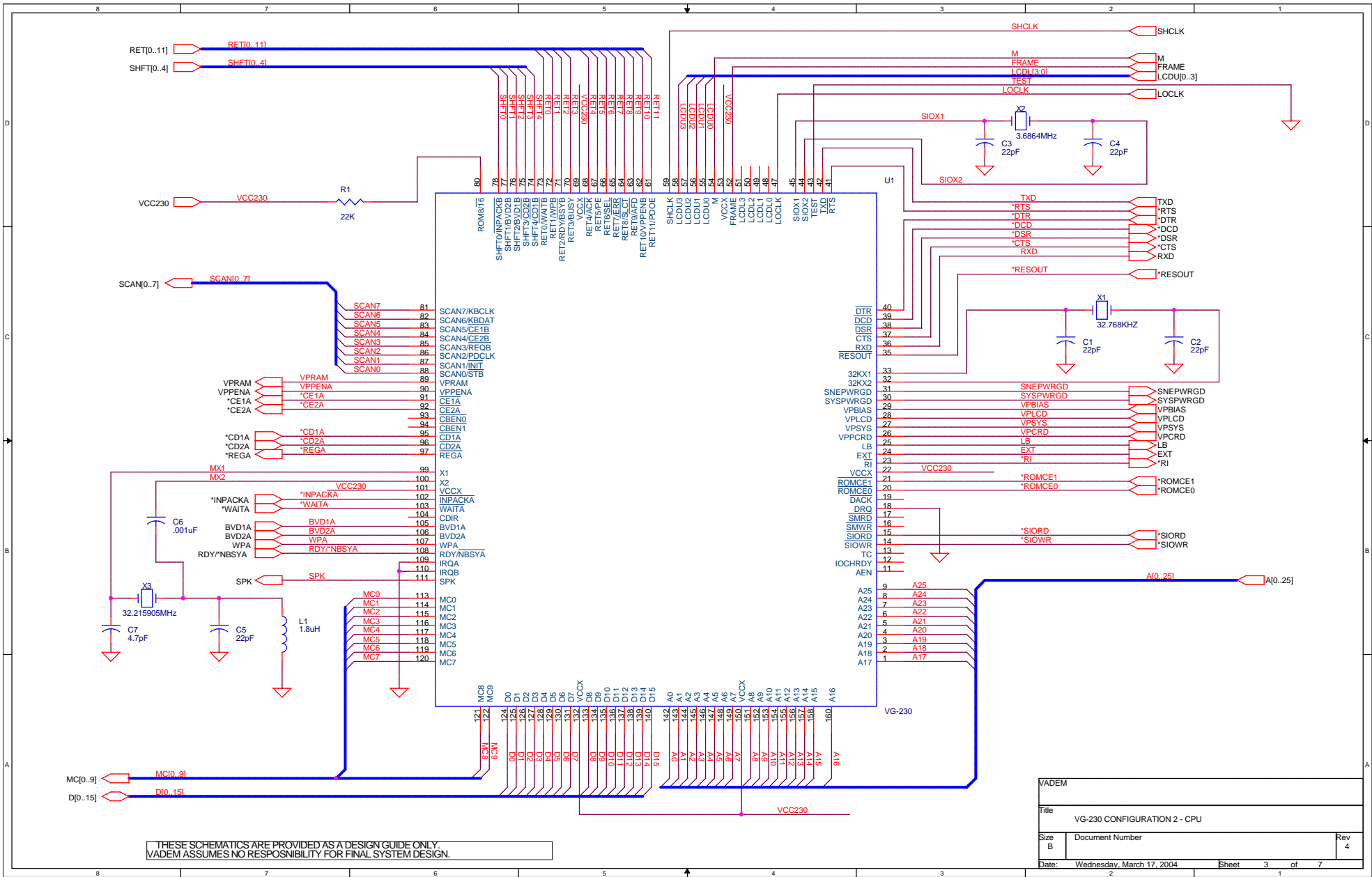

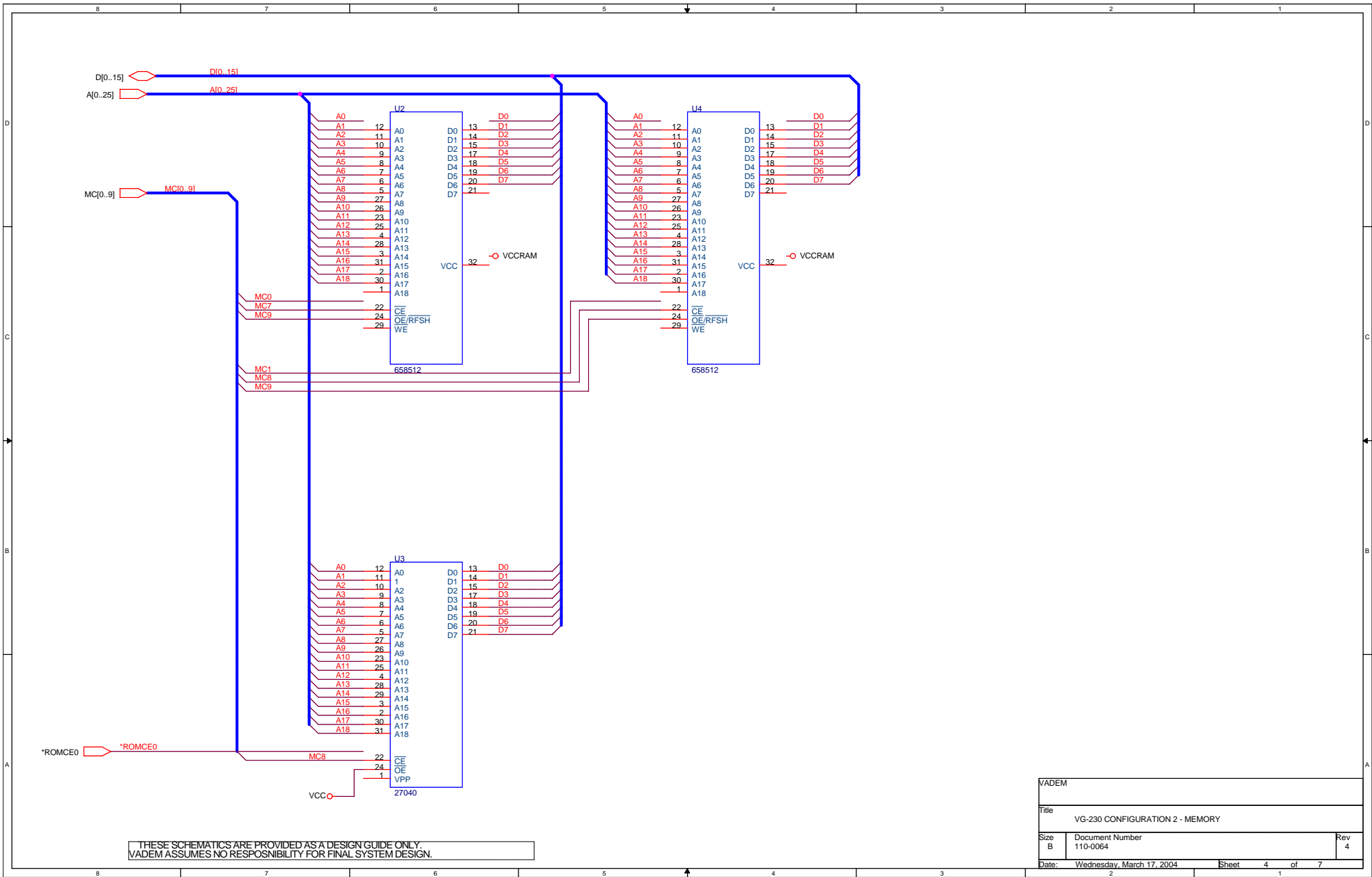

THESE SCHEMATICS ARE PROVIDED AS A DESIGN GUIDE ONLY.
 VADEM ASSUMES NO RESPONSIBILITY FOR FINAL SYSTEM DESIGN.

VADEM		
Title VG-230 CONFIGURATION 2 - MEMORY		
Size B	Document Number 110-0064	Rev 4
Date: Wednesday, March 17, 2004	Sheet 4 of 7	

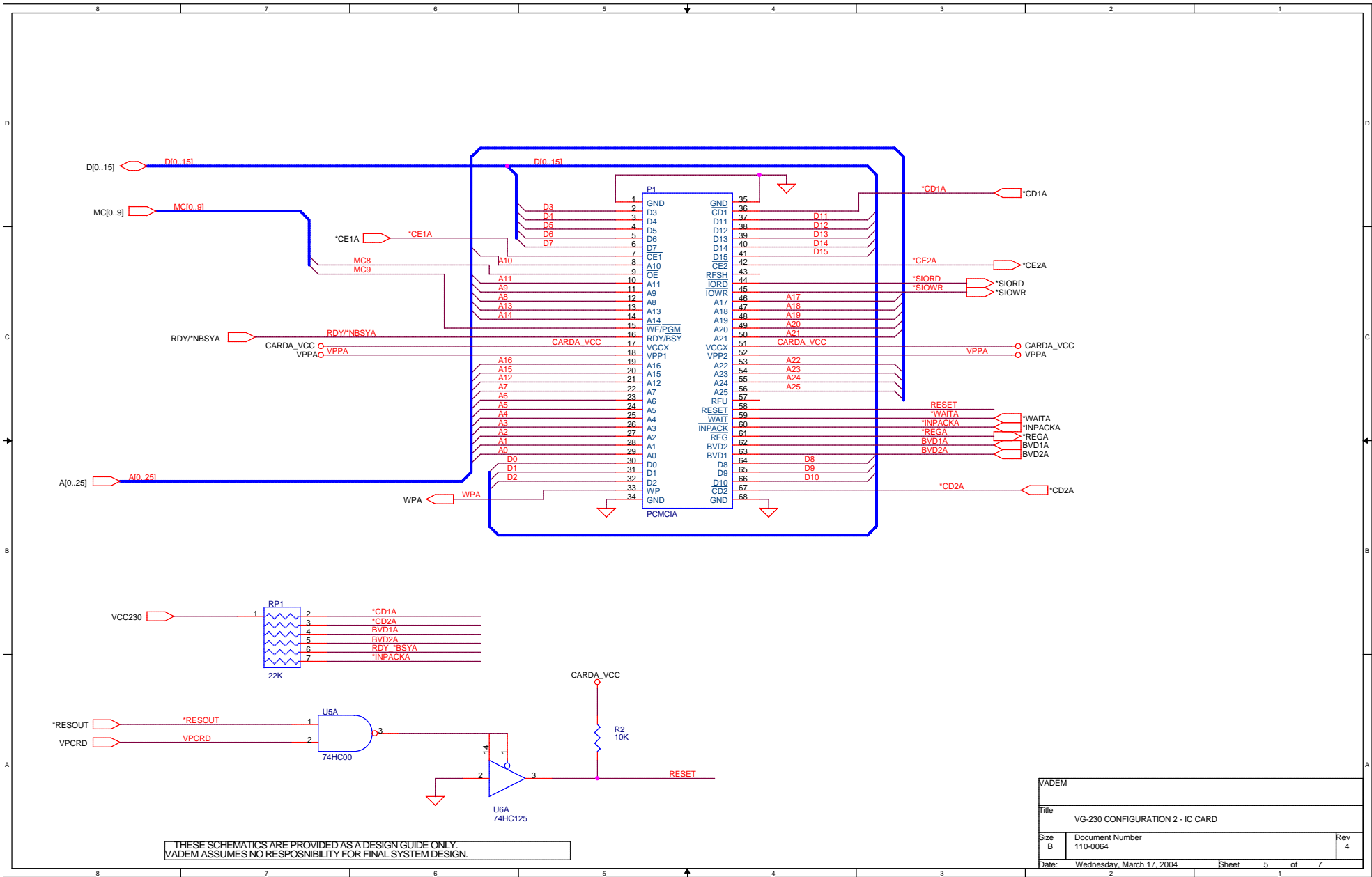

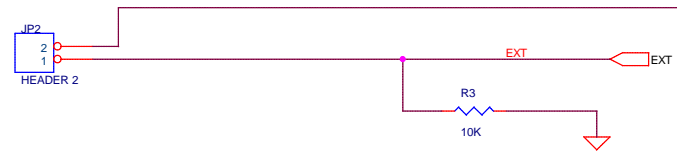
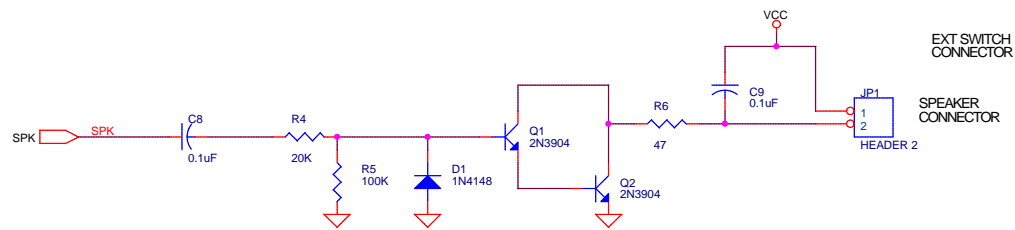
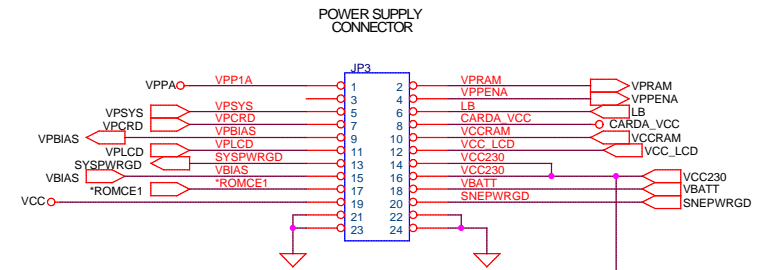
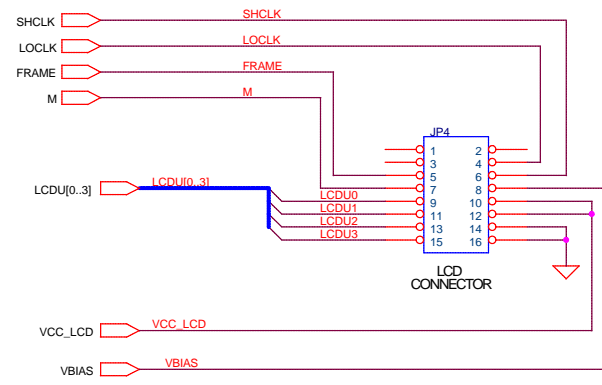
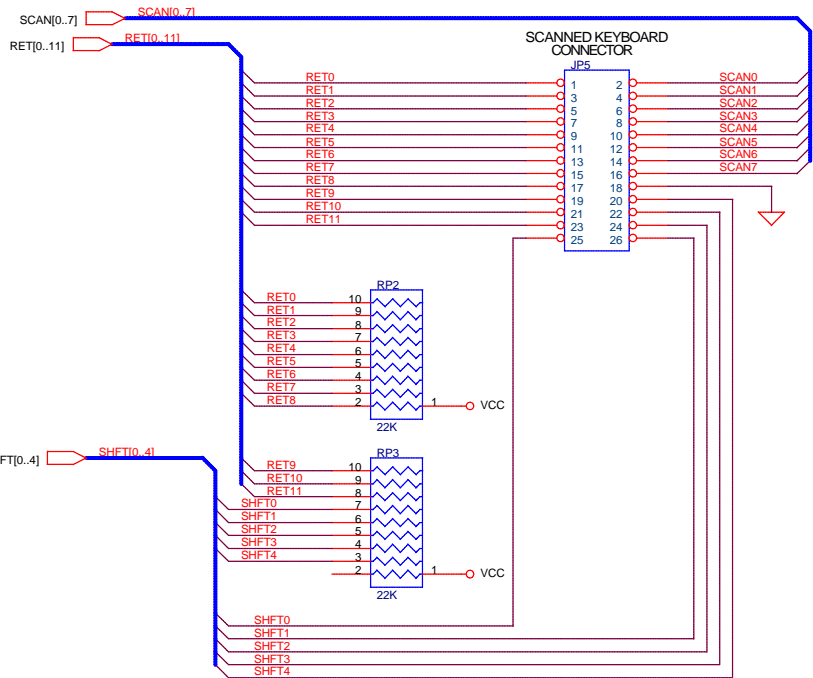

THESE SCHEMATICS ARE PROVIDED AS A DESIGN GUIDE ONLY. VADEM ASSUMES NO RESPONSIBILITY FOR FINAL SYSTEM DESIGN.

VADEM		
Title VG-230 CONFIGURATION 2 - KEYBOARD INTERFACE		
Size B	Document Number	Rev 4
Date: Wednesday, March 17, 2004	Sheet 6	of 7

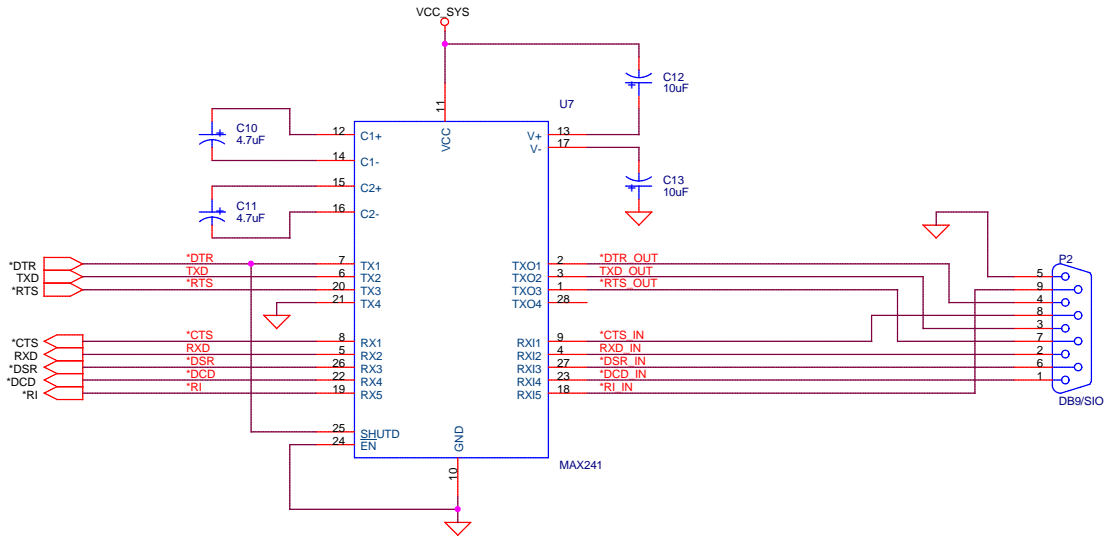

THESE SCHEMATICS ARE PROVIDED AS A DESIGN GUIDE ONLY.
VADEM ASSUMES NO RESPONSIBILITY FOR FINAL SYSTEM DESIGN.

VADEM		
Title VG-230 CONFIGURATION 2 - SIO CONNECTOR		
Size B	Document Number	Rev 4
Date: Wednesday, March 17, 2004	Sheet 7 of 7	