

BLOCK DIAGRAM



A_CFG3

VG-230



B_CFG3

KEYBOARD OPTION



C_CFG3

MEMORY



D_CFG3

PCMCIA SLOT

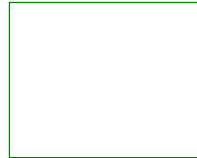

E_CFG3

SIOLCD CONNECTORS



F_CFG3

THESE SCHEMATICS ARE PROVIDED AS A DESIGN GUIDE ONLY.
VADEM ASSUMES NO RESPONSIBILITY FOR FINAL SYSTEM DESIGN.

Title		
VG-230 SAMPLE SCHEMATICS - CONFIG. 3		
Size	Document Number	Rev
B		4
Date:	Wednesday, March 17, 2004	Sheet 1 of 7

VG-230 - CONFIGURATION 3

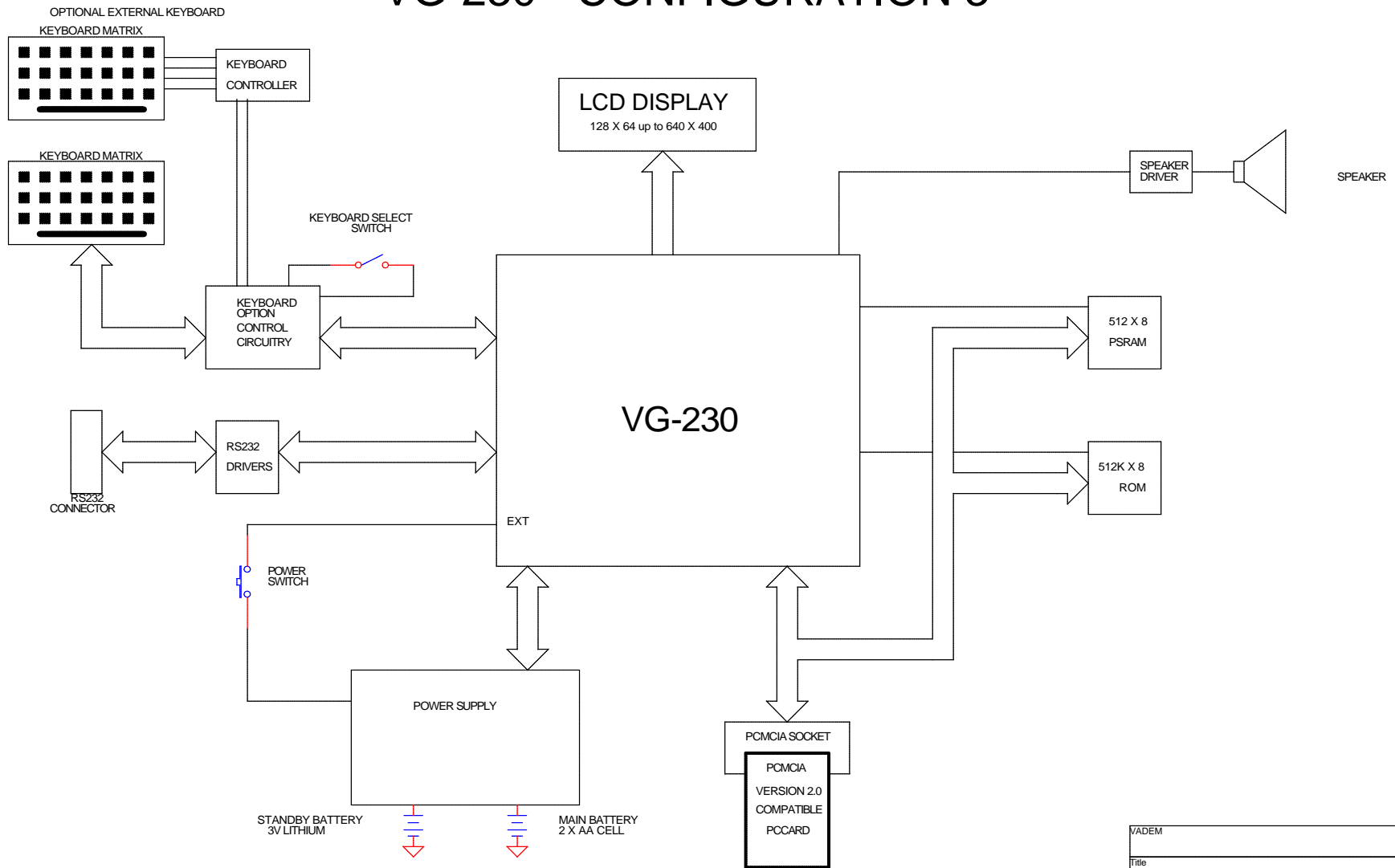

THESE SCHEMATICS ARE PROVIDED AS A DESIGN GUIDE ONLY.
 AMPHUS/VADEM ASSUMES NO RESPONSIBILITY FOR FINAL SYSTEM DESIGN.

VADEM		
Title VG-230 CONFIGURATION 3 - BLOCK DIAGRAM		
Size B	Document Number	Rev 4
Date: Wednesday, March 31, 2004	Sheet 2 of 7	

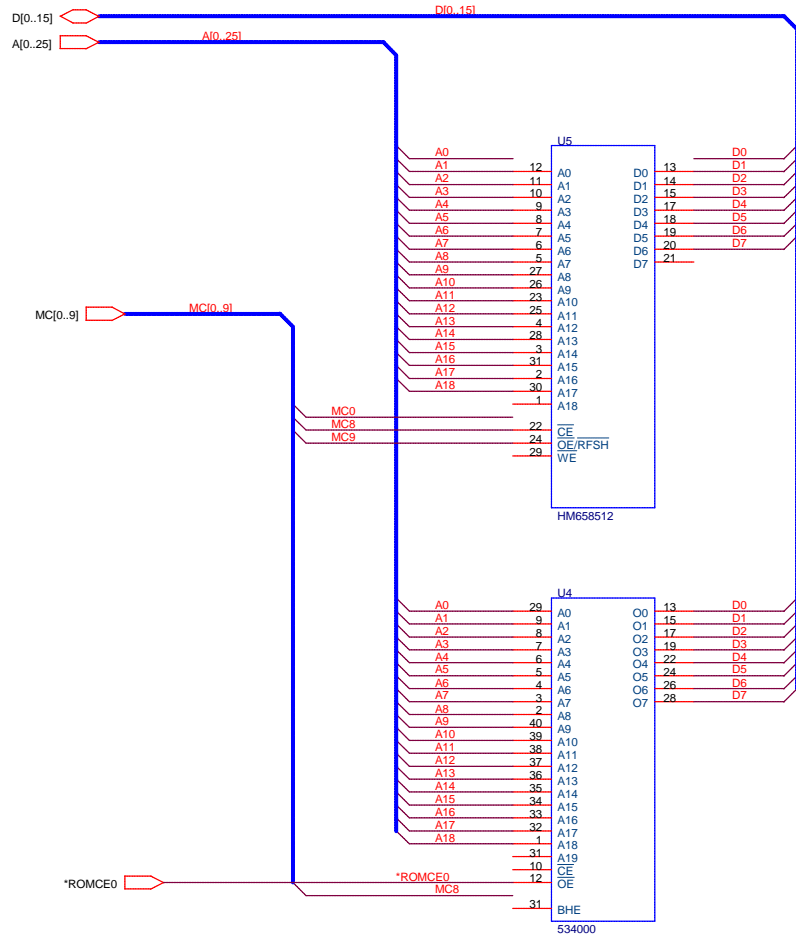

THESE SCHEMATICS ARE PROVIDED AS A DESIGN GUIDE ONLY.
 VADEM ASSUMES NO RESPONSIBILITY FOR FINAL SYSTEM DESIGN.

VADEM		
Title VG-230 CONFIGURATION 3 - MEMORY		
Size B	Document Number	Rev 4
Date: Wednesday, March 17, 2004	Sheet 5 of 7	

PCMCIA CONNECTOR

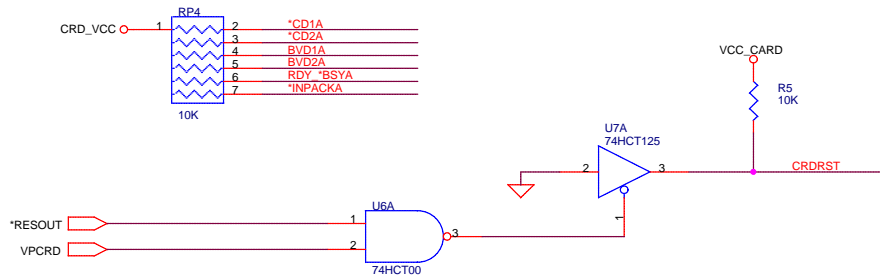
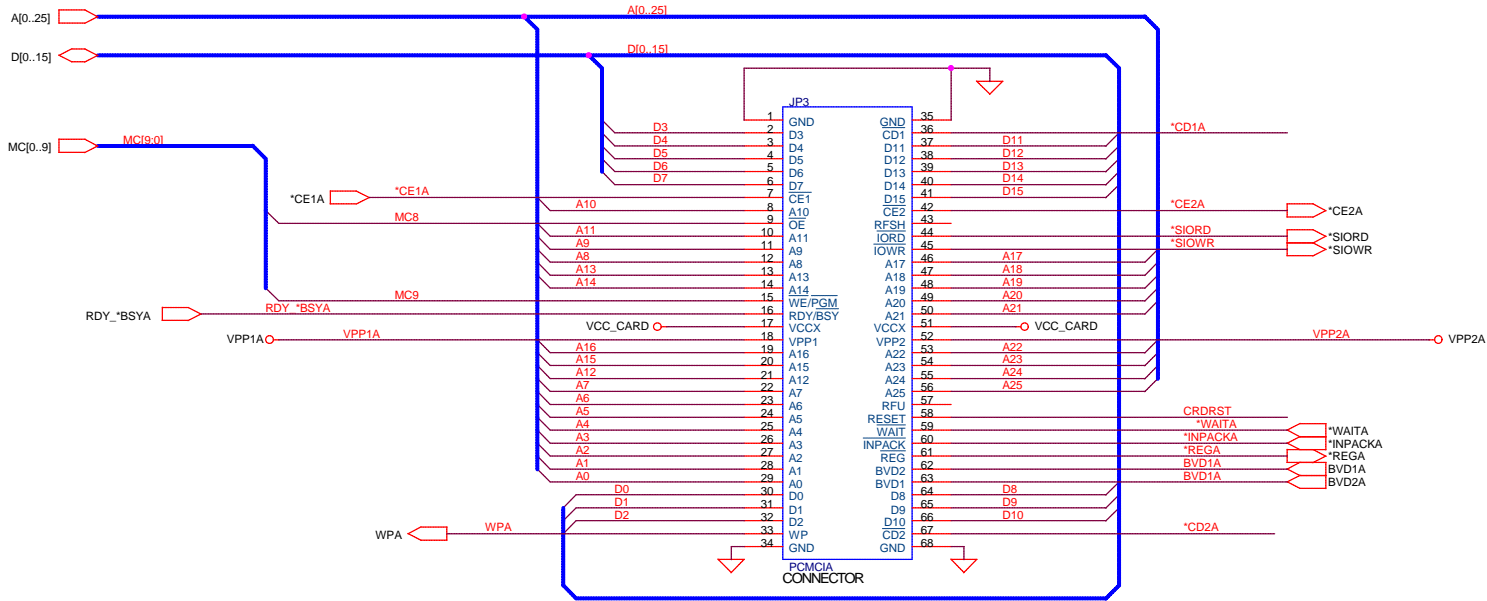

THESE SCHEMATICS ARE PROVIDED AS A DESIGN GUIDE ONLY.
 VADEM ASSUMES NO RESPONSIBILITY FOR FINAL SYSTEM DESIGN.

VADEM		
Title VG-230 CONFIGURATION 3 - PCMCIA SLOT		
Size B	Document Number	Rev 4
Date: Wednesday, March 17, 2004	Sheet 6	of 7

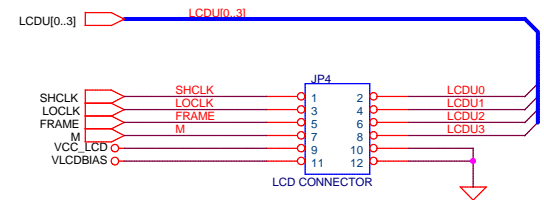
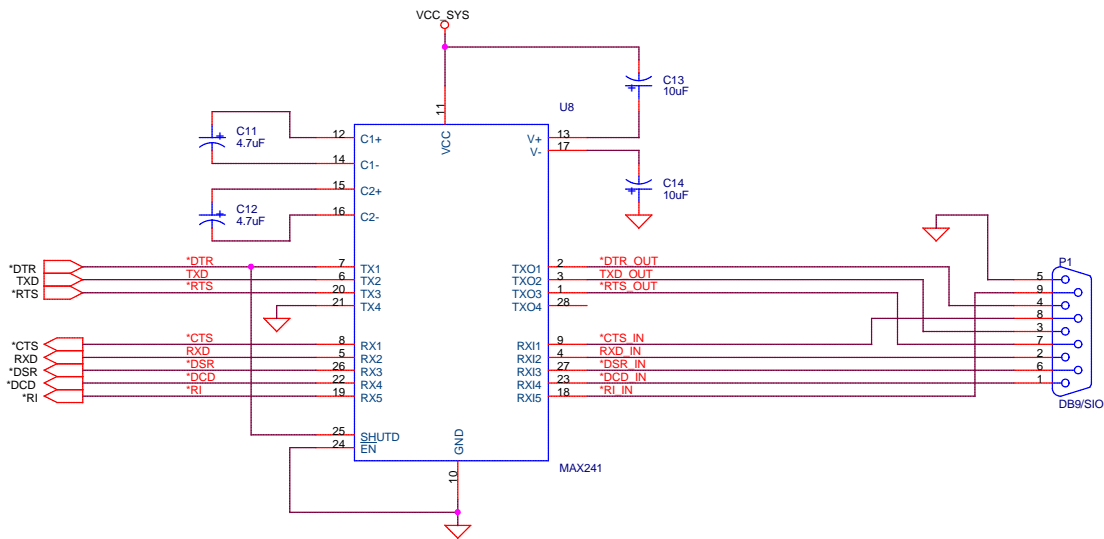

THESE SCHEMATICS ARE PROVIDED AS A DESIGN GUIDE ONLY.
VADEM ASSUMES NO RESPONSIBILITY FOR FINAL SYSTEM DESIGN.

VADEM		
Title VG-230 CONFIGURATION 3 - SIO/LCD CONNECTORS		
Size B	Document Number	Rev 4
Date: Wednesday, March 17, 2004	Sheet 7 of 7	